



# **FLEXPAK™ 3000**

## **TWO-BUTTON PROGRAMMING SET-UP / CONFIGURATION / TROUBLESHOOTING / OPERATION / PARTS MANUAL**

**First Production xxxx-6208DS  
December 15, 1994**

**Revised November 11, 1998  
803,902,350.11**

# TABLE OF CONTENTS

Introduction .....	Page 3
Models and Specifications .....	Page 4
Installation and Set-Up .....	Pages 5 thru 9
Features.....	Pages 10 & 11
Hardware Configuration.....	Page 12
FlexPak™ 3000 Audit Features .....	Pages 13 & 14
Audit Data Available through External Electronic Counters.....	Page 13
Audit Data Available through Service Menu.....	Page 14
Audit Data Available through Electronic Access.....	Page 14
Controller Programming .....	Pages 15 thru 23
Programming Quick Reference .....	Page 24
Troubleshooting:	
Coin/Currency .....	Pages 26 & 27
Sold-Out .....	Page 28
Vending .....	Pages 29 & 30
Display .....	Pages 31 & 32
Refrigeration.....	Pages 33 thru 39
Parts Diagrams and Lists.....	Pages 40 thru 54
Sample Wiring Diagram.....	Page 55
FlexPak™ 3000 Ardac Controllers Diagram.....	Page 56
FlexPak™ 3000 DeAmertek Controllers Diagram.....	Page 57
Appendix A1	Standard Factory Module Setting - DMV 72 & 79W
Appendix A2	Standard Factory Module Setting - DMV 72N (not available at print)
Appendix A3	Sample Internal Module Layouts
Appendix A4	Package Module Row Flexibility Matrix
Appendix A5	Package Set-Up Information

# INTRODUCTION

Dixie-Narco's FlexPak™ 3000 Vender is the next "generation" of equipment that will revolutionize the industry by providing a piece of equipment, in three models, that will serve your entire business. The FlexPak™ 3000 will provide full package flexibility with increased product capacity and exceptional space-to-sales. Each of the three models utilize standardized parts, delivery platform, and a refrigeration system that is 100% CFC-free.

The FlexPak™ 3000 also incorporates electronics to meet the growing need for accountability, multi-pricing, programmability, and system diagnostics. Along with these functions, DEX/UCS - communications to a hand-held computer is required for the bottling industry to provide the ability to measure each vending location for product performance, vender performance, and accessing accounting data. The data obtained can be used to maximize the efficiency of the truck routes for servicing venders. DEX communications provides the bottler security for the integrity of the "cash in" versus the "product sold".

# MODELS AND SPECIFICATIONS

## DMV 72N

Dimensions: 72"H x 28"W x 32"D

Approximate Weight: Not available at print

Number of Modules per Vender (12 oz. Can): 16

Number of Modules per Vender (16 oz. Bottle): 6, four 12 oz. can modules may be added

Number of Modules per Vender (20 oz. Bottle): 6, four 12 oz. can modules may be added

## DMV 72W

Dimensions: 72"H x 37"W x 32"D

Approximate Weight: 750 lbs. (Empty)

Number of Modules per Vender (12 oz. Can): 20

Number of Modules per Vender (16 oz. Bottle): 10

Number of Modules per Vender (20 oz. Bottle): 10

## DMV 79W

Dimensions: 79 1/2"H x 37"W x 32"D

Approximate Weight: Not available at print

Number of Modules per Vender (12 oz. Can): 20

Number of Modules per Vender (16 oz. Bottle): 10

Number of Modules per Vender (20 oz. Bottle): 10

All weights, dimensions, and specifications listed are subject to change without notice.

# INSTALLATION AND SET-UP

Please read this manual in its entirety. Repair and maintenance of this vending machine must only be performed by authorized and competent technical personnel. If you have any questions, please call your local bottler, distributor, or Dixie-Narco for assistance.

## Receiving Inspection

Upon receipt, inspect the FlexPak™ 3000 for shipping damage. If there is any damage, have the driver note the damage on the Bill of Lading and notify Dixie-Narco. Although I.C.C. regulations require that the consignee originate shipping damage claims, Dixie-Narco will gladly help if you must file a claim.

## Unpacking The Vender

Remove the stretch wrap and top covers from the vender. If flavor cards were shipped with the vender, they will be in an envelope affixed to the back of a vender in the shipment or in the cash box.

**NOTE: DO NOT STORE THE VENDER OUTDOORS WITH STRETCH WRAP ON. THIS COULD CAUSE THE STRETCH WRAP TO BOND TO THE VENDER'S SURFACE, WHICH COULD DAMAGE THE FINISH.**

Remove the shipping boards from the bottom of the vender. The shipping boards are attached by the leveling legs. Remove the shipping boards by **unscrewing** the leveling legs. This will avoid unnecessary damage to the leveling legs or the base. A 1-1/2" "socket-type" wrench should be used on the bottom of the leveling legs. Be sure to replace the legs after removing the shipping boards.

To open the vender, locate the door lock keys which are secured inside the coin return cup. After unlocking the door, rotate the "T"-handle counter-clockwise until the door can be opened. Once inside, check the coin box on the door for any additional parts, pricing labels, or information concerning factory equipped accessories. Check the "T"-handle for proper alignment and locking functions. Check the lamps for proper installation.

**WARNING: INSURE THAT POWER IS DISCONNECTED FROM THE VENDER OR THAT THE POWER INTERRUPT SWITCH (IF PROVIDED) IS NOT DEFEATED BEFORE INSPECTING OR REPLACING THE LAMPS. FAILURE TO COMPLY WITH THESE INSTRUCTIONS MAY SUBJECT THE USER TO THE RISK OF INJURY OR ELECTRICAL SHOCK WHICH CAN BE SERIOUS OR FATAL.**



## Electric Power Needed

Refer to the FlexPak™ 3000 serial number plate to determine the proper voltage and frequency the machine requires (domestically this requirement is 115 volt, 60 hertz). The vender will operate at +/- 10% of the specified voltage for domestic models - this is between 103 volts and 127 volts. Single phase, alternating current is required. The vender must be plugged in its own properly rated circuit with its own circuit protection (fuse/circuit breaker).

**DO NOT USE AN EXTENSION CORD.**

## Ground The Vender

The FlexPak™ 3000 is equipped with a three wire power supply cord and **MUST** be plugged into a properly grounded outlet.

**DO NOT REMOVE THE GROUND PIN OR IN ANY WAY BYPASS THE GROUNDING OF THE FLEXPAK 3000.** If the outlet will not accept the power cord plug, contact an electrician to install a proper AC outlet.



**WARNING:** Failure to comply with these instructions may subject the user to the risk of injury or electrical shock which can be serious or fatal.

## Placing The Vender On Location

**CAUTION: DO NOT TRANSPORT THE VENDER TO OR FROM THE LOCATION WHEN IT IS LOADED WITH PRODUCT; DAMAGE TO THE VENDER MAY RESULT.**

**The vender must be located on a solid, flat, and level surface.**

The vender must be positioned close enough to an electrical outlet that an extension cord is not required. If securing the vender to the floor or wall is required, call the Dixie-Narco Factory Service Department for suggestions.

## Level The Vender

Level the vender. When the vender is level, the door can be opened to any position and it will not move by itself. Open the door to several different positions before deciding that the vender is level. Make sure that all of the leveling legs are in contact with the floor. If you cannot level the vender, select another location. Do not place any objects under the machine.

**DANGER: THE VENDER MUST BE PROPERLY LOCATED AND LEVELED TO MINIMIZE THE RISK OF INJURY OR DEATH FROM TIPPING IN THE EVENT OF MISUSE OR VANDALISM.**

## Space The Vender

Do not block the rear of the vender. Maintain a minimum of 10 cm (4 in) from the wall to insure adequate air flow to the condenser and compressor. At the front of the vender, make sure that nothing obstructs the air intake at the bottom of the main door. At the rear of the vender, make sure that nothing obstructs the air exhaust at the bottom of the cabinet.

## Installing Flavor Cards

The flavor cards are inserted in the selection buttons. On non-TBV machines, swing the coin changer mounting plate away from the outer door exposing the back of the select buttons. The flavor cards are inserted in the back of the selection buttons from either side or remove the flavor card carrier. Ensure the flavor cards are placed in the select button flavor card carrier position that corresponds to the module in which the product is loaded. Install the flavor card carrier back in position. In TBV machines, carefully remove the select button lens from the select button. Insert the flavor card in the lens. Snap the lens back in position in the select button. Ensure the flavor cards are placed in the select buttons that correspond to the module in which the product is loaded.

# Temperature Control Adjustments

## Adjustment #1 - Temperature Adjustment

Turn the adjustment clockwise for colder product and counter-clockwise for warmer product. This will change the cut-out temperature only, the cut-in temperature remains constant.

## Adjustment #2 - Altitude Adjustment



**Warning:** Disconnect power to the vending machine before proceeding with this adjustment.

The control is factory set for an altitude of 152 M (500 ft.). For higher altitudes, adjust the inside range screws to prevent freeze-up of the product. Adjust the inside range screws as follows.

ALTITUDE		CUTLER-HAMMER 9531N272
Meters	(Feet)	Turn both screws counter-clockwise
610	(2,000)	1/8 Turn
1219	(4,000)	1/4 Turn
1829	(6,000)	1/2 Turn
2438	(8,000)	5/8 Turn

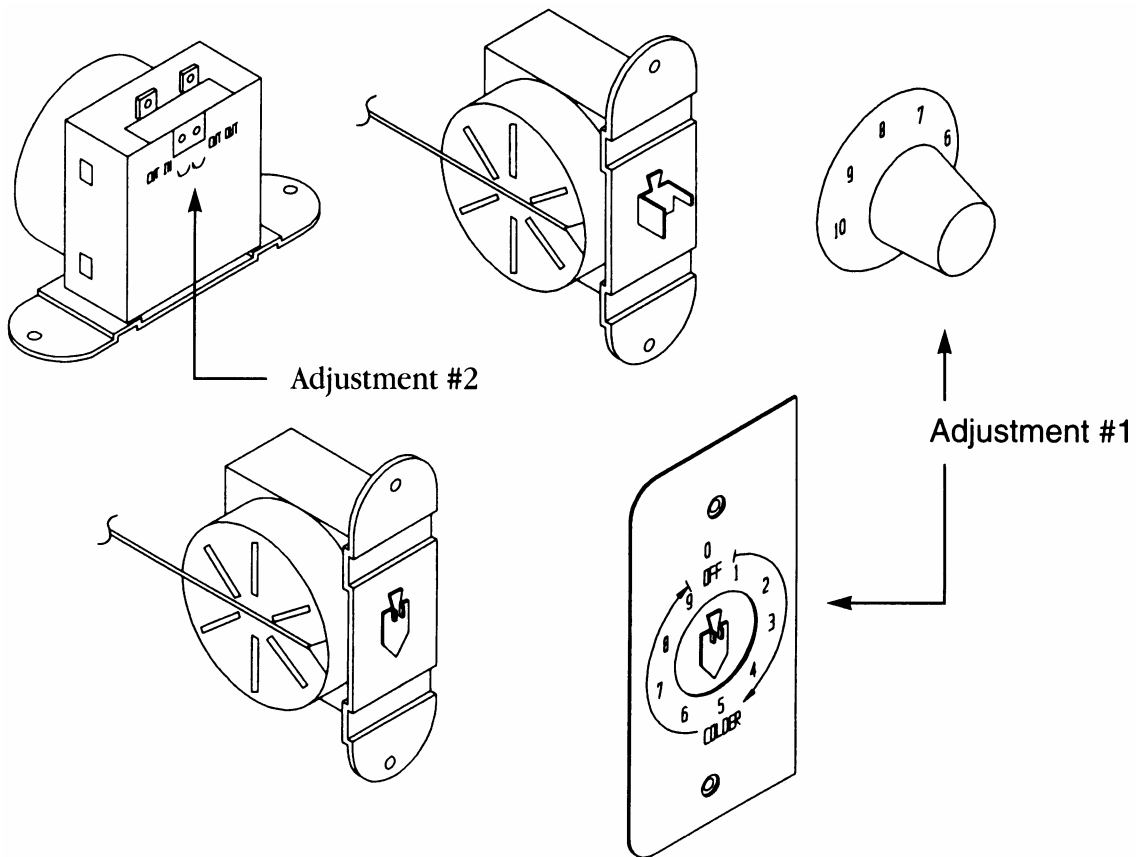



# Loading Instructions

## Product Vending

Dixie-Narco venders are shipped ready to vend 12 oz. cans unless another package was specified at the time the vender was ordered. If packages other than 12 oz. cans are to be vended, contact the Dixie-Narco Factory Service Department for the proper instructions.

The closure strip and the discharge member are set for the maximum security when vending cans. To vend bottles, refer to the illustration below.

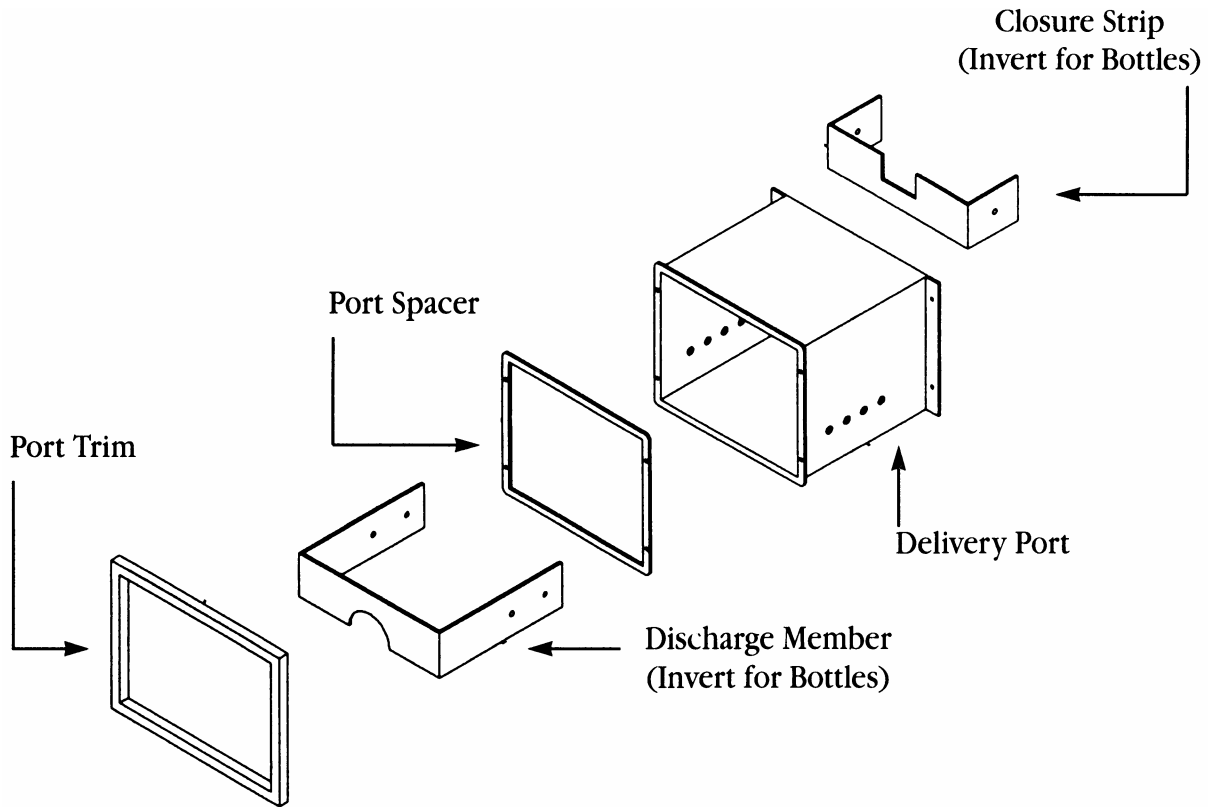

## Cleaning The Vender



**DO NOT USE A WATER JET OR NOZZLE TO CLEAN THE VENDER**

### Sign Face

The polycarbonate sign face requires proper cleaning to prolong the service life of this item. It is recommended that you periodically clean the sign as follows:

1. Rinse the sign with a soft cloth or sponge soaked in warm water.
2. If necessary, use a mild soap to loosen any dirt or grime. To prevent damage, **DO NOT SCRUB** or use a brush or squeegee, as some signs have a clear ultraviolet resistant coating to prevent yellowing.
3. Repeat the above steps as necessary, then dry using a soft cloth to prevent spotting.

### Cabinet

- \* Wash the cabinet with a good detergent or soap mixed in warm water.
- \* Wax the vender often with a good grade of automobile wax.
- \* Any corrosion inside of the vender should be removed with fine steel wool and the area should be painted with aluminum paint.
- \* Repair any scratches on painted surfaces to prevent corrosion.



**WARNING: THE COMPRESSOR ELECTRICAL CIRCUIT IS ALWAYS LIVE WHEN THE PLUG IS CONNECTED TO AN ELECTRICAL OUTLET.**

### Refrigeration Condenser

- \* Check the condenser periodically for dirt or lint build-up.
- \* Remove the build-up with a brush or vacuum, or blow the dirt out of the condenser with compressed air and approved safety nozzle.
- \* Ensure nothing obstructs the air intake at the bottom of the main door.
- \* Ensure nothing obstructs the air exhaust at the rear of the cabinet.

### Coin Acceptor

- \* Follow the coin acceptor manufacturer's instructions on cleaning.

## Lubricating The Vender

The FlexPak™ 3000 Refrigeration System does not require any field lubrication. The hermetic refrigeration system and fan motors are manufactured with lifetime lubrication.

### Parts Needing Lubrication

<u>Time</u>	<u>Component</u>	<u>Lubricant Example</u>
Every six months (or as needed)	<u>Main door</u> <ol style="list-style-type: none"><li>1. Lock Bolt &amp; Nut Retainer</li><li>2. Hinge Pivot Points</li></ol>	Mechanics Friend Mechanics Friend
	<u>Inner Door</u> <ol style="list-style-type: none"><li>1. Hinge Pivot Points</li></ol>	Mechanics Friend
Every Year	<u>Slides</u> <ol style="list-style-type: none"><li>1. Top Only</li></ol>	White Lithium Grease
	<u>Inner Door</u>	

(or as needed)

1. Door Gasket

Petroleum Jelly

# **FEATURES**

## **DEX COMPATIBLE HAND-HELD INTERFACE**

The vending industry (NAMA) has established an audit data protocol which is defined by DEX (Direct Exchange of Data) and UCS (Uniform Communications Standards). This interface is a direct connection as defined by the specification. The FlexPak™ 3000 has provisions for an internal and external connection. The external connection provides a limited amount of information.

## **20 MODULE COMPATIBLE**

The FlexPak™ 3000 cabinet controller is capable of driving up to twenty vend mechanisms independently. The vend mechanism is 24V DC.

## **LOW VOLTAGE SELECT PANEL**

The select panel consists of gold cross-point switches. The interface circuitry is located on the door control board. The control board supports up to fourteen selections.

## **PROGRAMMABLE SPACE-TO-SALES**

The programmable space-to-sales is a feature which allows modules to be assigned to select buttons. Modules are dispensed evenly when more than one module is assigned to given select button(s).

## **SELECT PANEL OR HAND-HELD CONTROLLER PROGRAMMING**

The FlexPak™ 3000 has the capability to be programmed through the select panel or through the DEX port on the door control board with the same hand-held used to access the accounting data.

## **LED DISPLAY (LIGHT EMITTING DIODES)**

Early displays consist of four characters, utilizing seven segment LED's for each character, to provide an alpha-numeric display. Current displays consist of four characters, utilizing fourteen segment LED's for each character, to provide an alpha-numeric display.

## **PRICE DISPLAY**

If all selections are set at the same vend price in primary pricing and secondary pricing, the vend price is shown on the display. If multi-pricing is used, pressing any select button shows the vend price of that particular selection on the display.

## **SINGLE PRICE OR MULTI-PRICE VIA THE SELECT PANEL OR HAND-HELD**

Prices for each selection can be programmed either through the front select panel or through the DEX hand-held device. For single price configuration, each selection has to be programmed for the same price. To set all selections for the same price:

- 1.) Enter "S-P" mode in the menu,
- 2.) Set desired vend price on select button 1,
- 3.) Simultaneously press and hold select buttons 3 and 4 for five seconds, this will change the vend price of all selections to the price programmed to select button 1.

## **ACCOUNTING DATA PROVIDED**

The accounting features can be accessed through the front select panel. These include **(Hd)** historical data, which is not resettable and **(Rd)** which is resettable.

### **(Hd)** Historical Data Includes:

- The total cash collected by the vender
- The total number of vends by the vender
- The total number of vends by each selection

### **(Rd)** Resettable Data Includes:

- The total cash collected since the last counter reset
- The total number of vends since the last counter reset
- The number of vends by each selection since the last counter reset and allows the resettable data to be zeroed.

The types of data that can be retrieved via the dex interface to a hand-held device is addressed in the Audit Features section on pages 13 and 14.

## **LIMITED ACCESS ON SELECTION (TIME, DAYS, PRICE)**

The limited access feature allows each selection to be inhibited with respect to time and selected days of the week. Also, prices of selections can be altered (Happy Hour) with respect to time and selected days of the week.

## **COIN CHANGER INTERFACES**

1.) The FlexPak™ controller supports the listed multidrop bus coin mechanisms.

Coinco 9302GX                      Mars TRC 6510

**CAUTION: DO NOT USE 24V CHANGERS. Use of 24V changers will cause damage to electronics package and changer and void all warranties.**

## **BILL VALIDATOR INTERFACES**

Dixie-Narco USA	(need 804,910,020.01 & 804,910,030.01 harnesses from Dixie-Narco)
Mars VFM-1	(need 804,910,020.01 & 804,910,030.01 harnesses from Dixie-Narco and 01-12-065-4 harness from Mars)
Mars VFM-3	(need to set dip switch #8 of VFM-3 to on -\$1.00 only or off -\$1.00 and \$5.00, need 804,910,020.01 & 804,910,030.01 harnesses from Dixie-Narco and 01-12-065-4 harness from Mars)
Mars VN2512 (mdb)	(need 250071009 harness from Mars)
Mars VN2511 (110VAC)	(need 804,910,020.01 and 804,910,030.01 harnesses from Dixie-Narco and 01-12-065-4 and 250077006 harnesses from Mars)
BA30-multidrop bus	(need 407420 interface harness from Coinco)
Conlux mdb-multidrop bus	

## **MULTIDROP BUS CAPABLE DEBIT CARD AND DATA RECORDING SYSTEMS**

The FlexPak™ 3000 is capable of interfacing to debit card and data recording systems which are multidrop bus acceptable. At this time, only a few such accessories have been tested by Dixie-Narco. If such accessories are to be used, check with either Dixie-Narco or the accessory manufacturer about physical and electrical compatibility before attempting to interface such accessories to the FlexPak™ 3000 vender.

# HARDWARE CONFIGURATION

The hardware configuration for the FlexPak™ 3000 consists of a cabinet control board, a door control board, and a display board or a door/display board combination. The select panel consists of low voltage switches and interfaces directly to the door control board.

The vend mechanism is 24V DC. The vend mechanism interfaces directly to the cabinet controller.

The main (primary) fuse is located either on the transformer mounting plate or on the cabinet control board.

The cabinet control board is the main controller. It supports up to twenty vend mechanisms. It senses product in the delivery chute and controls the dispensing from modules. It also controls the door control board and the collection of money and change payout.

The door control board reports the status of the door to the cabinet control board. It reports the status of the door switch, select panel, service switch, DEX port, changer, and note acceptor. The door control board enables and disables the changer and note acceptor. It also tests the display as commanded by the cabinet control board.

The vend sensor recognizes the product being delivered and reports directly to the cabinet control board.

The door switch is included to determine door accesses. A service switch, located on the door control board, is used to access accounting data and programming features through the front select panel.

The DEX interface supports both an internal connection as well as an external connection. The interconnect is a 1/4" phono jack as specified and approved by the NAMA. The initial hand-held devices supported are Norand, Mars MEQ, Fujitsu, and lap top PC's. All electrical specifications, protocols, and baud rates are identified in the specification.

A real time clock (RTC) with battery backed memory is provided so memory can be maintained during power failures. The life expectancy of the battery is five years shelf and ten years operational. The real time clock is displayed in military time (24 hour clock). It is used for time stamping door closures, power outages, limited access, and selection discount pricing.

Early display boards consist of four, seven segment LED's to provide alpha-numeric characters. Current boards consist of four, fourteen segment LED's to provide clearer alpha-numeric characters. Also, the exact change indicator consists of an LED.

The intelligence of the cabinet (main) controller is a Motorola 68HC11 microprocessor. A minimum of 64K of Eprom and 8K of ram (battery backed) is provided.

# FLEXPAK<sup>®</sup> 3000 AUDIT FEATURES

The FlexPak<sup>™</sup> 3000 provides two methods of accessing audit data. A limited amount of audit information is available in the service menu. More extensive audit information is accessible electronically.

## SERVICE MENU

Six types of audit data are available in the service menu: Historical Data (**Hd**) which includes total cash collected, total vends and the total number of vends by each selection; Resettable Data (**Rd**) which includes total cash collected since the last counter reset, total vends since last counter reset, and total number of vends by each selection since the last counter reset.

The audit data is accessed by pressing the service switch. The display will show "**Hd**". Pressing select button 1 displays the total cash collected by the vender. Pressing select button 2 displays the total vends by the vender. Pressing select button 3 displays the total number of vends by each selection. Each selection is automatically scrolled across the display. Pressing select buttons 1 and 2 simultaneously will move to the next function. The display will show "**Rd**". Pressing select button 1 displays the total cash collected since the last counter reset. Pressing select button 2 displays the total vends since the last counter reset. Pressing select button 3 displays the total number of vends by each selection since the last counter reset.

## EXTERNAL ELECTRONIC COUNTERS

External electronic counters are used to show historical total vends, interval product counts that have occurred for prices being used, and interval product count for each selection from outside the vender. To set or change the four key code see "Ecnt" on page 19. To show the current data, hold the four keys programmed for five (5) seconds. The display will show historical total vends. To view other data:

Press and hold select button 1:	Show historical vends.
Press and hold select button 2:	Show list of prices and interval product counts that have occurred for those prices.
Press and hold select button 3:	Show interval product count for each selection.
Press and hold select button 4 For five (5) seconds:	Resets interval data. "COUnErS rESEt" will scroll across the display.
Press any select button greater than four or two (2) minutes of inactivity will return vender to normal operation.	

## ELECTRONIC ACCESS

A much more extensive amount of audit information is accessible electronically. It is retrieved with a portable data collection device and typically loaded into a computer at a central location. The data can then be tracked with a database, for preparing route stocking lists, tracking cash flow, doing inventory control, and other tasks. Data collection devices are available from several sources, including Norand, Fujitsu, Panasonic, Telxon, Verifone, and Mars. Dixie-Narco currently collects data with a PC program running on a portable notebook computer.

The FlexPak™ 3000 uses the DEX/UCS protocol as the method of exchanging data with the portable data collection device. DEX/UCS was formally adopted as the standard method of collecting audit data for the vending industry by the National Automatic Merchandising Association (NAMA) in April of 1991. DEX/UCS has been used in related industries since 1989. It was developed by the Arthur D. Little Company and is administered and maintained by the Uniform Code Council (UCC). The NAMA Vending Electronics Standardization Committee developed and published a comprehensive set of data records relevant to the vending industry. The FlexPak™ 3000 reports the portion of these related to this specific machine design. The current list of records and their usage by the FlexPak™ 3000 follows.

DEX stands for Direct Exchange of data, which means there is a hard-wired connection between the two systems exchanging data. This is done by inserting a 1/4 inch phone plug on the portable data collection device into a jack mounted on the FlexPak™ 3000 door controller. Inserting the plug automatically initiates the exchange of data, which takes several seconds. No other machine functions are available while the exchange is taking place. Most of the data records are reported in both an interval and historical format. The historical values represent a total of the values since the machine shipped from the factory. The interval values are the data collected since the last time it was collected electronically.

The following types of audit data are accessible electronically:

- Machine Identity Information
- Date and Time of Interrogation
- Cash Sales Summary
- Cash Input and Output Summary
- Product Sales Information
- Machine Configuration
- Events:            Door Openings                            Interrogations
- Time of Day Discounts Programmable Access Limits
- Sold-out Selection Information

In addition to retrieving audit data, every machine configuration parameter that can be programmed in the service menu can be programmed electronically via the DEX port.

The following types of data can be configured electronically:

- Machine Identity                            Limited Access Control Parameters
- Price & Product Information            Space-to-Sales
- Date and Time                              Time of Day Discounts Control Parameters

\*Escrow Mode

\* Escrow mode cannot be transferred with the Norand device.



# FLEXPAK<sup>®</sup> 3000 TWO BUTTON PROGRAMMING XXXX-6208DS & HIGHER

The controller has two modes of operation:  
NORMAL and SYSTEM SET-UP/AUDIT/DIAGNOSTICS

**NORMAL MODE:**

In normal mode, the display will show a decimal point.  
When money is inserted, the display indicates the total amount of the deposit. The select buttons are used to select the product.

**IMPORTANT:** Anytime "StS InIt" (Space-to-Sales Initialization) scrolls across the display, the FlexPak<sup>™</sup> controller has recognized a change from the programmed space-to-sales set-up. Press select button 2 to confirm the controller to not make any changes. Press select button 1 to allow the controller to change the FlexPak<sup>™</sup> space-to-sales set-up (re-initialize).

**SYSTEM SET-UP/AUDIT/DIAGNOSTICS MODE:**

System set-up/audit/diagnostics mode is entered when the vender inner door is open and the system set-up/audit/diagnostics switch is pressed. The display will show a list of error codes for errors that have occurred since the door was last opened. "SS-#" is a select switch problem, "us-1" is a vend sensor blocked or misaligned problem, "nP-#" is a NPN transistor failed (bad board) or stack harness problem, "Pn-#" is a PNP transistor failed (bad board), "S-#" is a solenoid failed, and "rE-#" is an unplugged row. To acknowledge an error, press any select button, at this time you will enter the menu. The display will show "Hd" at this time. Some of the menu items have sub-menus. To move through the menus and sub-menus follow these instructions.  
To:

- |                    |   |
|--------------------|---|
| MOVE THROUGH MENU: | Push select buttons 1+2 simultaneously to scroll down through the menu. While scrolling down through menu, release, push select buttons 1+2 simultaneously to scroll up through menu. |
| ENTER SUB-MENU:    | Push and hold select button 1 to enter a sub-menu.  |
| EXIT SUB-MENU:     | With "rtn" on display, push and hold select button 1 to exit a sub-menu.  |

**EXIT SYSTEM SET-UP/AUDIT/DIAGNOSTICS MODE:**  
Closing the inner door or a two minute inactivity time-out will exit the system set-up/audit/diagnostics mode.

## FRONT PANEL PROGRAMMING SYSTEM SET-UP/AUDIT/DIAGNOSTICS MENU

**Hd - Historical Data:**

This section shows the user the vender accounting over the life of the vender. Use the following select buttons to view the total sales in dollars, total number of vends and the total number of vends for each selection.

- |                       |   |
|-----------------------|---|
| Press Select Button 1 | Shows the historical total cash sales for the life of the vender.   |
| Press Select Button 2 | Shows the historical total number of vends.   |
| Press Select Button 3 | Shows the historical number of vends by selection. Each selection automatically scrolls across the display. |

Press & hold select buttons 1+2 simultaneously to move to next item on menu.

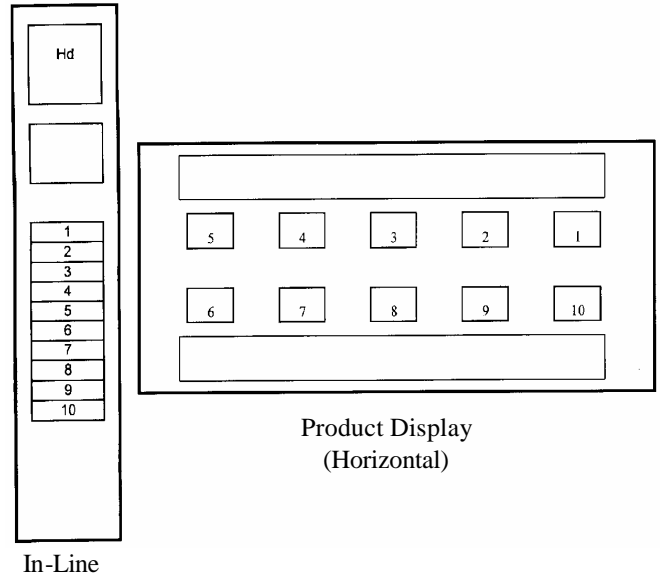

**rd - RESETTABLE DATA:**

This section shows the user the vender accounting data since the time of the last counter reset. This data can be reset either from this menu or by a DEX interrogation.

- Press Select Button 1: Shows the total cash collected since the last counter reset.
- Press Select Button 2: Shows the total number of vends since the last counter reset.
- Press Select Button 3: Shows the total number of vends by selection since the last counter reset. Each selection automatically scrolls across the display.
- Press Select Button 4: This button zeros the resettable data described above. Hold button "4" for 5 seconds and "COUnTErS rESEt" will be displayed. At this time, all resettable data will return to "0".

Press & hold select buttons 1+2 simultaneously to move to next item on menu.

**S-P - SET PRICE:**

This function is used to set the price of each selection. When a select button is pushed, the price for that selection will be displayed. If the button is held in, the price will increment or decrement. To change from increment to decrement, release the select button and push it again. To set all selections for the same price: 1) set desired vend price on select button #1, 2) simultaneously push and hold select buttons 3+4 for five seconds, this will change the vend price of all selections, both primary and secondary, to the price programmed to select button #1.

Note: The Flexpak multi-pricing capability allows you to set all selections to any price in the range of \$0.00 to \$99.95.

Press & hold select buttons 1+2 simultaneously to move to next item on menu.

**C-d - COIN DUMP/COIN FILL MODE:**

**C-d - COIN DUMP:**

This section is used to dump coins from the coin mechanism while in "C-d" mode.

- Press & hold Select Button 1: Dump Nickels.
- Press & hold Select Button 2: Dump Dimes.
- Press & hold Select Button 3: Dump Quarters.

**C-d - COIN FILL MODE:**

This section is used to count coins loaded in the top (separator) of the coin mech. Insert coins in the top (separator) of the coin mech. The total value of the coins will be displayed and will be counted in the DEX audit data, so the Flexpak controller knows exactly how much change is in the coin mech.

Press & hold select buttons 1+2 simultaneously to move to next item on menu.

**USEr - USER OPTIONS MENU**

This function is used to configure the vender to operate in the fashion best suited for the vender location. To move to diagnostics (DIA6), press & hold select buttons 1+2 simultaneously, to enter the sub-menus press select button 1. The following are sub-menus of the User Option Menu: "StS", "tInE", "dAtE", "ESC", "Lan6", "PrOn", "Ecnt", "nF", "bILL", "LIn", "SEC", "FrEE", and "rtn".

**StS - SPACE TO SALES:**

To view the space to sales condition, push any select button to display the current modules assigned to that select button. To change space to sales condition:

To Add Selection:

Depress Set-Up Switch, "Add" will be displayed. Note: Pressing the set-up switch will toggle between add and delete. A 10 second inactivity time-out will return to "StS". Push and hold any select button, whichever select button you are holding is the select button the additional module will be assigned. While holding the select button, the display will read "Add #" and the selection will increment from 1 to 20. Release select button when the desired module # to be added is displayed. A message will scroll across the display telling you what module will be assigned to the button you were holding. Depress Set-Up switch to complete space to sales decision and re-enter service mode.

To Remove Selection:

Depress Set-Up Switch, "Add" will be displayed, depress set-up switch again and "dEL" will be displayed. Note: Pressing the set-up switch will toggle between add and delete. A 10 second inactivity time-out will return to "StS". Push and hold any select button, the select button you are holding is the select button from which the additional module will be removed. While holding select button, the display will read "dEL #" and the selections will increment from 1 to 20. Release select button when the desired module # to be removed is displayed. A message will scroll across the display telling you what module will be deleted from the button you were holding. Depress Set-Up Switch to complete space to sales decision and re-enter service mode.

NOTE: Only one space-to-sales change may be made at a time. The set-up/audit/diagnostics switch must be pressed before and after each change.

Press & hold select buttons 1+2 simultaneously to move to next item on menu.

**tmE - TIME:**

To display time, push and let go of any select button. Time will be displayed in military time (24 hour clock). To change time, press and hold select button 1-hours or 2-minutes, the time will increment or decrement. To change from increment to decrement, release the select button and push it again. To change time:

Press & hold Select button 1: set hours.

Press & hold Select button 2: set minutes.

Press & hold select buttons 1+2 simultaneously to move to next item on menu.

**datE - DATE:**

To view date, push and let go of select button 1 or 2 to display month and day. Month and day will be displayed as "X.YY" where "X" represents the month and "YY" represents the day. Push and let go of button "3" to display day of week, push and let go of button "4" to display year.

To change date:

Press & hold Select Button 1: set Month

Press & hold Select Button 2: set Day

Press & hold Select Button 3: set Day Of Week

Sunday	1	Thursday	5
Monday	2	Friday	6
Tuesday	3	Saturday	7
Wednesday	4		

Press & hold Select Button 4: set Year

Press & hold select buttons 1+2 simultaneously to move to next item on menu.

**ESC - ESCROW:**

This section supports 4 (four) escrow options. To show the current escrow condition, push any select button. To change the escrow condition:

Press & hold Select Button 1      **"Pr" - Escrow to Price**

The escrow condition is "escrow to price". All dollar bills will be stacked. No cancel sale is allowed once minimum vend price is met or exceeded.

Press & hold Select Button 2      **"E-S4" - Escrow to Select 4**

The escrow condition is "escrow to select" with all dollar bills being stacked. Cancel sale will return the deposit from the coin changer (i.e. 4 quarters).

**Press & hold Select Button 3 "E-S1" - Escrow to Select 1**

The escrow condition is "escrow to select" with the last dollar bill that meets or exceeds maximum vend price being escrowed in the validator. Cancel sale will return the held dollar bill and any amount over \$1 will be returned from the coin changer.

**Press & hold Select Button 4 "E-P2" - Escrow No Cancel**

The escrow condition is "escrow no cancel" with all bills stacked, and no cancel sale allowed unless the vender is in exact change and the maximum vend price is exceeded. Note: Any money entered below the vend price cannot be returned.

Press & hold select buttons 1+2 simultaneously to move to next item on menu.

**Lan6 - LANGUAGE**

This function is used to set the language that will be used for display messages. To display the current language selected, press any select button. To change the language selected, press and hold the appropriate select button until the display shows the new language selected.

Select Button 1:	English	En6L
Select Button 2:	German	6erN
Select Button 3:	Spanish	Spn
Select Button 4:	French	Frn
Select Button 5:	Italian	ItA

**PrOn - PROMOTIONAL SALES**

This function is used to initiate a promotional sale. To show the current promotional condition:

Press Select Button 1:	To show "Un-X", where X equals the number of vends required to initiate promotion.
Press Select Button 2:	To show "Fr-X", where X equals the number of free beverages to be delivered after the number of vends have occurred as programmed.
Press Select Button 3:	To show "EnAbLEd SEL #(s)" of the selections that are enabled for the promotion.

To change the promotional sales conditions:

Press & hold Select Button 1: The number of vends required to initiate the promotional sale will increment from zero to 25 and then return to zero. Release the select button when the desired number of vends to initiate the promotional sale is displayed.

Note: If "Un-0", the promotion is disabled.

Press & hold Select Button 2: The number of free beverages to be delivered after the number of vends have occurred will increment from zero to 25 and then return to zero. Release the select button when the desired number of free beverages to be delivered is displayed.

Note: If "Fr-0", the promotion is disabled.

Press & hold Select Button 3: Display will show "EnAbLEd SEL #(s)" where # shows the selections that are enabled for the promotion to occur. To add or delete selections:

- A) Press the system set-up/audit/diagnostics switch. The display will show "Add", indicating selections will be added. Press the system set-up/audit/diagnostics switch again and the display will show "dEL", indicating selections will be deleted.
- B) Press and hold any select button. The display will show "Add #" or "dEL #", where # is a select button number. While holding a select button, the # will increment from 1 to the maximum select button number and return to 1.
- C) Release the select button when the desired selection # to be added or deleted is displayed. A message will scroll across the display, telling you what selection will be added or deleted.
- D) Press the system set-up/audit/diagnostics switch to complete the decision.

Note: Only one selection may be made at a time. The system set-up/audit/diagnostics must be pressed before and after each change.

Important: Promotional sales, when enabled, will be on at all times of the day.  
Press & hold select buttons 1+2 simultaneously to move to next item on menu.

## **ECnt - ELECTRONIC COUNTER**

This function is used to show historical total vends, interval product counts that have occurred for prices being used, and interval product count for each selection from outside the vender. To program the Flexpak to use this function, press any select button. The current setting or four (4) key programming will be displayed. If "----" no code is programmed. To program or to change four (4) key program:

- A) Press system set-up/audit/diagnostics switch. Display will show "----", indicating the new code is ready to be entered.
- B) Press the four (4) select buttons that are desired to be in the code. As they are pressed, the display will change to show the four (4) select buttons chosen. Note: Four (4) separate buttons must be used or the pattern will not be saved. Note: Only select buttons 1 through 9 may be used.
- C) Press the system set-up/audit/diagnostics switch. The display will change back to "Ecnt". To show the current count, hold the four keys programmed for five (5) seconds. The display will show historical total vends. To view other data:

Press & hold Select Button 1: Show historical total vends.  
Press & hold Select Button 2: Show list of prices and interval product counts that have occurred for those prices.  
Press & hold Select Button 3: Show interval product count for each selection.  
Press & hold Select Button 4 for five seconds: Resets interval data. "COUnTerS rESEt" will scroll across display.  
Press any select button greater than 4 will return the vender to normal operation.

Note: There is a two (2) minute time-out that will return the vender to normal vending mode.

Press & hold select buttons 1+2 simultaneously to move to next item on menu.

## ***nF - Note Factor (for use with foreign note acceptors only)***

*Some foreign note acceptors that use a pulsed signal to indicate the value of the note being accepted must have the value of that pulse (the note factor) programmed in the vender. The Flexpak will determine the value of the note inserted by multiplying the number of pulses counted by the Note Factor programmed.*

*To show the current Note Factor "nF" condition: Push any select button and the current value will be displayed.*

*To change the Note Factor "nF" condition: Push and hold any select button. The Note Factor will increment or decrement from 100 to 10000. To change from increment to decrement, release the select button and push it again. Domestically, Note Factor should be set at 100.*

*Note: The decimal point position will be communicated by the coin mech to the Flexpak control board.*

*Press and hold select buttons 1 & 2 simultaneously to move to next item on menu.*

## **bILL - SET BILLS ONLY**

To enter "bILL", go to "bILL" in the sub-menu.

To show the current "bILL" condition: Push select button 1 and the current condition will be displayed.

To change the "bILL" condition:

Select Button 1: When pressed, enables "bills yes" mode. You no longer need to use a changer; the controller will operate with bills only.

Select Button 2: When pressed, enables "bills no" mode. You need to use a changer; the controller will not operate the note acceptor without a changer.

## **LIn - LIMITED ACCESS MENU**

This function is used to program the vender to use the Limited Access Features. To move to Secondary Price Menu, "SEC", press & hold select buttons 1+2 simultaneously, to enter the sub-menu press select button 1. The following are sub-menus of Limited Access Menu: "LAOS", "LAOd", "Per1", "PER2", and "rtn".

**LAOS - LIMITED ACCESS ON SELECTION:**

This function is used to set selection(s) which will be limited during certain periods of the day. To view the limited access on selection condition, press any select button. The display will show "EnAbLEd SEL - #(s)" where # shows the selections that are set for limited access. To change limited access on any selection, push and hold the desired select button until the message displayed is the desired limited access condition for that selection.

EnAbLEd SEL - #(s) - Selection(s) displayed are on limited access.

EnAbLEd SEL - All selections are not on limited access.

Press & hold select buttons 1+2 simultaneously to move to next item on menu.

**LAOd - LIMITED ACCESS ON DAYS:**

This function is used to set the days of the week for limited access. To view the limited access on days condition, push and let go of any select button. The display will show "EnAbLEd On dAYS - #(s)"

Day of Week:

Sunday	1	Wednesday	4	Saturday	7
Monday	2	Thursday	5		
Tuesday	3	Friday	6		

To change limited access on days:

To Add Days:

Push set-up switch, "Add" will appear on display. Push and hold any select button to scroll through days. Release select button at desired day to turn on limited access. Push set-up switch to complete limited access on days decision. This must be done for each day to be added.

To Remove Days:

Push set-up switch, "Add" will appear on display. Push set-up switch again, "dEL" will appear on display. Push and hold any select button to scroll through days. Release select button at desired day to turn off limited access on that day. Push set-up switch to complete limited access on days decision. This must be done for each day to be removed.

NOTE: Only one limited access on days change may be made at a time. The set-up/audit/diagnostics switch must be pressed before and after each change.

Press & hold select buttons 1+2 simultaneously to move to next item on menu.

**PEr1 - PERIOD 1:**

This function is used to set time to start and end limited access. To display PEr1 start time, push and let go of select button **1 or 2**. To display PEr1 end time, push and let go of select button **3 or 4**.

To Change:

PEr1 Start Time:

To change start time, hold select button **1** to change hours, and select button **2** to change minutes. The time will increment or decrement. To change from increment to decrement, release the select button and push again.

PEr1 End Time:

To change end time, hold select button **3** to change hours, and select button **4** to change minutes. The time will increment or decrement. To change from increment to decrement, release the select button and push again.

Note: Start time has to be less than end time. You must set an on and off time when using PEr1.

Press & hold select buttons 1+2 simultaneously to move to next item on menu.

**PEr2 - PERIOD 2:**

Set time to start and end limited access the same as period 1.

Limited access can be enabled for two different periods in one day. Period 2 must be greater than period 1.

Press & hold select buttons 1+2 simultaneously to move to next item on menu.

**rtn - RETURN:**

This function is used to return to the User Menu.  
Press select switch 1+2 simultaneously to return to "LAOS".  
Press select switch 1 to return to the User Option Menu at "LIn".  
Press & hold select buttons 1+2 simultaneously to move to next item on menu.

**SEC - SECONDARY PRICE MENU**

This function is used to program a second price for each selection. To enter the sub-menu press select button 1. The following are sub-menus of Secondary Price Menu: "S-P2" ,"Pr2P" ,"Pr2d" and "rtn". To move to User Options Menu press select buttons 1+2 simultaneously until "rtn" shows on display. Press select switch 1 to return to "USER".

**S-P2 - SET SECONDARY PRICE:**

This function is used to set a secondary price for each selection. When a select button is pushed, the price for that selection will be displayed. If the button is held in, the price will increment or decrement. To change from increment to decrement, release the select button and push it again.  
Press & hold select buttons 1+2 simultaneously to move to the next item on menu.

**Pr2P - SET SECONDARY PERIOD:**

This function is used to set time to start and end secondary prices. To display Pr2P start time, push and let go of select button **1 or 2**. To display Pr2P end time push and let go of select button **3 or 4**.

To Change:

Pr2P Start Time:

To change start time, hold select button **1** to change hours, and select button **2** to change minutes. The time will increment or decrement. To change from increment to decrement, release the select button and push again.

Pr2P End Time:

To change end time, hold select button **3** to change hours, and select button **4** to change minutes. The time will increment or decrement. To change from increment to decrement, release the select button and push again.

There is only one period in a day for enabling secondary pricing.

Note: Start time has to be less than end time. You must set an on and off time when using Pr2P.

Press & hold select buttons 1+2 simultaneously to move to next item on menu.

**Pr2d - SET SECONDARY DAYS**

This function is used to set the days of the week for secondary pricing. To view the Pr2d push and let go of any select button. The display will show "EnAbLEd On dAYS -".

Day of Week:

Sunday	1	Wednesday	4	Saturday	7
Monday	2	Thursday	5		
Tuesday	3	Friday	6		

To change Pr2d:

To Add Days:

Push set-up switch, "Add" will appear on display. Push and hold any select button to scroll through days. Release select button at desired day to turn on Pr2d. Press set-up switch to complete Pr2d decision. This must be done for each day to be added.

To Remove Days:

Push set-up switch, "Add" will appear on display. Push set-up switch again, "dEL" will appear on display. Push and hold any select button to scroll through days. Release select button at desired day to turn off Pr2d. Press set-up switch to complete Pr2d decision. This must be done for each day to be removed.

NOTE: Only one secondary pricing on days may be made at a time. The set-up/audit/diagnostics switch must be pressed before and after each change.

Press & hold select buttons 1+2 simultaneously to move to "rtn".

Press select button 1 to return to "SEC".

Press & hold select buttons 1+2 simultaneously to move to the next item on menu.



## **FrEE - FREE VEND ENABLE**

This function is used to allow 14 select or less venders to be set on free-vend using a mechanical switch. The free-vend enable must be turned on for the switch to allow free-vend, and a free-vend switch kit must be installed. (Contact Dixie-Narco Factory Service for information on the free-vend switch kit.)

Press Select Button 1: Toggle free-vends on (enabled) and off (disabled).  
Press Select Button 2: To Display number of free-vends.  
Press Select Button 3: To clear or reset the free-vend counter.

Press and hold select buttons 1+2 simultaneously to move to the next item on menu.

## **rtN - RETURN:**

This function is used to return to the User Options Menu.

Press select buttons 1+2 simultaneously to move to "rtN".

Press select button 1 to return to "USEr".

Press & hold select buttons 1+2 simultaneously to move to the next item on menu.

## **dIA6 - DIAGNOSTICS MENU**

This function allows you to systematically diagnose problems related to the vender. To move to "AutO" press select button 1+2 simultaneously, to enter sub-menu press select button 1. The following are sub-menus of Diagnostics Menu: "SE-", "nt-", "uS", "Cn", "nA", "dSP", "uErS", "undr", and "rtN".

### **"SE-" - Select Switch Test**

Press any select button, and the display will indicate the number of the select button pressed.

Press & hold select buttons 1+2 simultaneously to move to the next item on menu.

### **"nt-1" - Motor Test**

Use this test to cycle any vend mechanism. Use the following select buttons to run this test.

Select Button 1: Press until desired vend mechanism # to run is shown on the display.

Select Button 2: Press to cycle the selected vend mechanism. The display will show "tESin6" and the selected vend mechanism will cycle.

Press & hold select buttons 1+2 simultaneously to move to the next item on menu.

### **"uS-" - Vend Sensor**

This function allows you to check the alignment and proper functioning of the vend sensor. The display will change from "uS-0" to "uS-1" as the sensor becomes blocked and unblocked.

### **"Cn" - Coin Mech Test**

Use this test to test coin mech programming, coin chute work, and coin mech payout systems.

Insert coins. The value of coins will be reflected on display.

Press & hold Select Button 1: Displays the Coin Mechanism setting.  
"ndb" - Multi Drop Bus interface

Press & hold Select Button 2: Returns the coins inserted

Press & hold select buttons 1+2 simultaneously to move to the next item on menu.

### **"nA" - Note Acceptor Test**

Use this test to test acceptor function.

Insert note. The value of note will be reflected on display.

Press & hold Select Button 1: Displays the Note Acceptor setting. ("LL" - low level or  
"ndb" - multi-drop note acceptor)

Press & hold Select Button 2: Stacks the note and cancels the credit shown on display.

Press & hold Select Button 3: Returns the note and cancels the credit shown on display.

Press & hold select buttons 1+2 simultaneously to move to the next item on menu.

**"dSP" - Display Test**

Press any select button and the display segments will illuminate in a scrolling manner, while blinking the exact change LED.  
Press & hold select buttons 1+2 simultaneously to move to the next item on menu.

**"uErS" - Version of Software**

Press any select button and the display will scroll the software revision level in the control box.  
Example: 57 526-X. "X" represents the installed software revision.  
Press & hold select buttons 1+2 simultaneously to move to the next item on menu.

**rtm - RETURN TO MAIN MENU**

Press & hold select buttons 1+2 simultaneously to return to "SE-".  
Press & hold select button 1 to return to "dIA6".  
Press & hold select buttons 1+2 simultaneously to move to next item on menu.

**"AutO" - Auto Test**

This test is used in Dixie-Narco's manufacturing process and is not intended for use in the field. Its purpose is a self-test routine to check the FlexPak™ 3000 System. For further details contact Dixie-Narco Factory Service.

# FLEXPAK<sup>®</sup> 3000 QUICK REFERENCE MENU PROMPTS

## Main Menu

Hd - Historical Data  
 rd - Resettable Data  
 S-P - Set Price  
 C-d - Coin Dump / Fill  
 USEr - Options Menu

## Sub-Menu

StS - Space-To-Sales  
 tInE - Time  
 dAtE - Date  
 ESC - Escrow  
 Lan6 - Language  
 PROn - Promotional Sales  
 Ecnt - External Electronic Counter  
 nF - Note Factor  
 bILL - Bills Only  
 Lin - Limited Access

## Sub-Menu

LAOS - Limited Access on Selection  
 LAOd - Limited Access on Days  
 Per1 - Period 1 for "Lin"  
 Per2 - Period 2 for "Lin"  
 rtn - Return

SEC - Secondary Price

S-P2 - Set Secondary Price  
 Pr2P - Set Secondary Period  
 Pr2d - Set Secondary Days  
 rtn - Return

FrEE - Free Vend Enable  
 rtn - Return

dIA6 - Diagnostics

SE- Select Switch Test  
 nt- Motor Test  
 uS - Vend Sensor Test  
 Cn - Coin Mech Test  
 nA - Note Acceptor Test  
 dSP - Display Test  
 uErS - Version of Software  
 rtn - Return

AutO - Auto Test

# TROUBLESHOOTING INDEX

Coin / Currency .....	Pages 26 & 27
Sold-Out .....	Page 28
Vending .....	Pages 29 & 30
Display .....	Pages 31 & 32
Refrigeration .....	Pages 33 thru 39
Product Hot:	
Compressor will not run .....	Page 33
Compressor starts but will not keep running .....	Page 34
Miscellaneous .....	Page 35
Product Cold But Not Cold Enough:	
Compressor runs but will not cool product .....	Page 36
Product Too Cold or Frozen:	
Compressor runs too long or continuously .....	Page 37
Noisy Refrigeration Unit .....	Page 38
Excessive Condensate .....	Page 39

## COIN / CURRENCY

SYMPTOM	POSSIBLE CAUSE	THINGS TO CHECK	WHAT TO DO
Will not accept coins.	Coin return lever stuck.	Make sure changer & lever are mounted properly.	Reposition or adjust changer or lever as needed.
	Power supply to vender.	Check for power at outlet.	Supply power to outlet.
		Check outlet circuit breaker or fuse.	Replace fuse or turn circuit breaker on.
	Power supply to cabinet control board.	Check power going to transformer.	Repair or replace damaged or bad parts.
		Check power going from transformer to board.	Repair or replace damaged or bad parts.
		Check 1.6 Amp primary power fuse.	Replace fuse if bad.
	Coin mech interface harness to door control board.	Check harness is plugged in.	Plug in harness.
		Check harness for backed out or cut wires.	Repair or replace damaged or bad parts.
		Check harnessing from door control board to cabinet control board.	Repair or replace damaged or bad parts.
	Changer.	Acceptor dirty or foreign matter in coin path.	Clean or replace acceptor.
		Check changer operation in diagnostics.	Replace changer with known good changer.
	Cabinet Control Board.	Check harnessing to and from cabinet control board.	Repair or replace damaged or bad parts.
Replace cabinet control board.			
Accepts coins but will not vend.	Coin mech interface harness to door control board.	Check harness for backed out or cut wires.	Repair or replace damaged or bad parts.
		Check harness from door control board to cabinet control board.	Repair or replace damaged or bad parts.
	Changer.	Check changer operation in diagnostics	Replace changer with known good changer.
	Cabinet Control Board.	Check harnessing to & from cabinet control board.	Repair or replace damaged or bad parts.
Replace cabinet control board.			
Changer will not pay out coins.	Coin mech interface harness to door control board.	Check harness for backed out or cut wires.	Repair or replace damaged or bad parts.
		Check harness from door control board to cabinet control board.	Repair or replace damaged or bad parts.
	Changer.	Check changer operation in diagnostics.	Replace changer with known good changer.
	Cabinet Control Board.	Check harnessing to and from cabinet control board.	Repair or replace damaged or bad parts.
Replace cabinet control board.			

<b>SYMPTOM</b>	<b>POSSIBLE CAUSE</b>	<b>THINGS TO CHECK</b>	<b>WHAT TO DO</b>
Incorrect change paid back.	Vend prices set incorrectly.	Prices in "S-P".	Set vend price to proper setting.
	Changer.	Check changer operation in diagnostics.	Replace changer with known good changer.
	Cabinet Control Board.	Check harnessing to & from cabinet control board.	Repair or replace damaged or bad parts. Replace cabinet control board.
Will not accept bills. Coin mech works.	Bill acceptor interface harness.	Is proper interface harness being used.	Use proper interface harness.
		Check harness(es) are plugged in.	Plug in harness.
		Check harness for backed out or cut wires.	Repair or replace damaged or bad parts.
		Check harness from door control board to cabinet control board.	Repair or replace damaged or bad parts.
	Changer.	Check for coins in coin mech.	Fill coin tubes.
	Bill Acceptor.	Check bill acceptor operation in diagnostics.	Replace bill acceptor with known good bill acceptor.
	Cabinet Control Board.	Check harnessing to and from cabinet control board.	Repair or replace damaged or bad parts. Replace cabinet control board.
Accepts bills and pays back incorrect change.	Vend prices set incorrectly.	Prices in "S-P".	Set vend price to proper setting.
	Note Factor set wrong in menu.	Go to "nF" (note factor) and ensure it is set to 100.	Set note factor to 100.
	Cabinet Control Board.	Check harnessing to and from cabinet control board.	Repair or replace damaged or bad parts. Replace cabinet control board.
Debit card system inoperable.	---	---	Contact debit card manufacturer for details.
Accepts bill but will not give credit.	Bill acceptor interface harness.	Is proper interface harness being used.	Use proper interface harness.
		Check harness(es) are plugged in.	Plug in harness.
		Check harness for backed out or cut wires.	Repair or replace damaged or bad parts.
		Check harnessing from door control board to cabinet control board.	Repair or replace damaged or bad parts.
	Bill Acceptor.	Check bill acceptor operation in diagnostics.	Replace bill acceptor with known good bill acceptor.
	Cabinet Control Board.	Check harnessing to and from cabinet control board.	Repair or replace damaged or bad parts. Replace cabinet control board.

## SOLD-OUT

SYMPTOM	POSSIBLE CAUSE	THINGS TO CHECK	WHAT TO DO
Sold out message stays on with product in all modules.	Vend Sensor.	Open main door, cycle door switch. If sold-out message goes away, vend sensor is O.K.	If sold-out message is still on display, go to next thing to check.
		Check vend sensor harness to cabinet control board.	Repair or replace any damaged or bad parts.
		Check vend transmitter and receiver for proper alignment.	Go to "uS" test in diagnostics and test. If out of alignment, make repairs.
	Cabinet Control Board.	Cabinet Control Board.	Replace if bad. Replace cabinet control board.
Sold-out message stays on with product in a given module.	Module not assigned to a select button.	Go to "StS" (Space-to-Sales) in menu and ensure module is assigned to a select button.	Assign module to a select button.
	Vend Mechanism.	Go to "nt" in diagnostics and ensure vend mechanism will cycle.	Replace vend mechanism.
		Check harness from vend mech to cabinet control board.	Repair or replace damaged or bad parts.
		Check wire at diode of affected module.	Replace module harness if bad.
	Product jammed or bridged above vend mechanism.	Incorrect product loaded in module.	Use proper module for product package.
		Package damaged or foreign debris causing jam/bridge.	Remove damaged package or foreign debris.
		Module damaged.	Replace module.
	Cabinet Control Board.	Check harness to and from cabinet control board.	Repair or replace damaged or bad parts.
Replace cabinet control board.			
Sold-out message appears for incorrect select button.	Module assigned to incorrect select button.	Go to "StS" (Space-to-Sales) in menu and ensure module is assigned to correct select button.	Assign module to correct select button.
	Module harness connected to incorrect module.	Check for proper wiring of module harness to modules.	Wire correctly.
	Cabinet Control Board.	Check harness to and from cabinet control board.	Repair or replace damaged or bad parts.
Replace cabinet control board.			
Sold-out message will not display on a given select button.	More than one module is assigned to the select button.	One of the modules assigned to the select button has product in it.	No repair needed.
	Cabinet Control Board.	Check harness to and from cabinet control board.	Repair or replace damaged or bad parts. Replace cabinet control board.
Sold-out message stays on for a given select button.	No product in modules assigned.		Load product in modules.
	No modules assigned to select button.		Assign module(s) to select button.

## VENDING

SYMPTOM	POSSIBLE CAUSE	THINGS TO CHECK	WHAT TO DO
Free vend on all select buttons.	Vend price set at 0.00.	Check price for select buttons set in "S-P"	Set prices.
	Secondary Pricing set at 0.00.	Check price for select buttons set in "S-P2".	Disable secondary pricing.
	Changer.	Check harness for backed out or cut wires.	Repair or replace damaged or bad parts.
		Check harness from door control board to cabinet control board.	Repair or replace damaged or bad parts.
		Check changer operation in diagnostics.	Replace changer with known good changer.
	Cabinet Control Board.	Check harnessing to and from cabinet control board.	Repair or replace damaged or bad parts.
Replace cabinet control board.			
Free vend on one select button.	Vend price set at 0.00.	Check price for select button set in "S-P".	Set Price.
	Secondary price set at 0.00.	Check price for select button set in "S-P2".	Disable secondary pricing.
	Cabinet Control Board.	Check harnessing to & from cabinet control board.	Repair or replace damaged or bad parts.
			Replace cabinet control board.
Jack-pot on one module.	Vend price set at 0.00.	Check price for select button set in "S-P".	Set price.
	Secondary price set at 0.00.	Check price for select button set in "S-P2".	Disable secondary pricing.
	Cabinet Control Board.	Check harnessing to and from cabinet control board.	Repair or replace damaged or bad parts.
			Replace cabinet control board.
I selection dry vends.	Product stuck in delivery chute.	Delivery chute aligned properly.	Align delivery chute.
Multiple modules assigned to select button not sequencing.	"StS" (Space-To-Sales" not set properly.	Check modules assigned to select button in "StS".	Assign modules to select button.
	Product jammed or bridged above vend mechanism.	Incorrect product loaded in module.	Use proper module for package.
		Package damaged or foreign debris causing jam/bridge.	Remove damaged package or foreign debris.
		Module damaged.	Replace module.
	Cabinet Control Board.	Check harnessing to and from cabinet control board.	Repair or replace damaged or bad parts.
Replace cabinet control board.			
Board power fuse blows when supplied power.	Module wiring.	Module wiring.	Repair or replace damaged or bad parts.
	Note acceptor and coin mech interface harness to door control board.	Check harness for backed out or cut wires	Repair or replace damaged or bad parts.
		Check harnessing from door control board to cabinet control board.	Repair or replace damaged or bad parts.
	Changer.	---	Replace changer with known good changer.
	Note Acceptor.	---	Replace note acceptor with known good note acceptor.
	Transformer	Check harnessing to and from transformer.	Repair or replace damaged or bad parts.
			Replace transformer.
Cabinet Control Board.	Check harnessing to and from cabinet control board.	Repair or replace damaged or bad parts.	



Replace cabinet control board.

SYMPTOM	POSSIBLE CAUSE	THINGS TO CHECK	WHAT TO DO
Multiple vends (press one select button & more than one product falls from different modules).	Promotional Sales set.	Check "PrOn" and see if it is enabled.	Disable "PrOn".
	Module Row Harness.	Check harnessing to and from module vend mechanisms.	Repair or replace damaged or bad parts.
	Cabinet Control Board.	Check harnessing to and from cabinet control board.	Repair or replace damaged or bad parts. Replace cabinet control board.
Multiple Vends (Press one select button and more than one product falls from a module)	Solenoid.	Spring of Solenoid.	Large end of spring should be against the solenoid body and the small end against the e-clip.
		Plunger of Solenoid.	Check for syrup build-up, which may cause sticking of plunger.
	Vend Mechanism.	Vend mechanism bracket and platform.	Check for syrup build-up. Check for platform mounting holes in bracket being too large. Check platform mounting tabs for excess flash.
One module will not cycle.	No product in module.	Check for product.	Install product.
	Module not assigned to a select button.	Check "StS" and see if module is assigned.	Assign module to a button.
	Vend Mechanism.	Go to "nt" in diagnostics and ensure vend mechanism will cycle.	Replace vend mech.
		Check harness from vend mech to cabinet control board.	Repair or replace damaged or bad parts.
		Check wire at diode of affected module.	Replace module harness if bad.
		Make sure vend mechanism bracket holds solenoid in place.	Replace vend mechanism bracket.
		Check for dirt or syrup build-up on bracket or platform.	Replace vend mechanism.
		Solenoid.	Replace solenoid.
		Product jammed or bridged above vend mech.	Incorrect product loaded in module.
	Package damaged or foreign debris causing jam/bridge.		Remove damaged package or foreign debris.
	Module damaged.		Replace module.
	Row harness.	Check harness is plugged in and is not damaged.	Plug in or replace row harness.
		Check diode.	Replace diode.
	Spacer	Check spacer setting.	Adjust spacer to allow package to vend.
	Cabinet Control Board.	Check harnessing to and from cabinet control board.	Repair or replace damaged or bad parts.
Replace cabinet control board.			
Select Button cycles incorrect module.	Module not assigned to correct select button.	Check "StS" and see if module assigned to correct select button.	Assign module to select button.
	Module harness.	Module harness not installed properly.	Connect module harness to correct vend mechanisms.
	Select panel harness.	Select panel harness not installed properly.	Connect module harness to correct vend mechanisms.

## DISPLAY

SYMPTOM	POSSIBLE CAUSE	THINGS TO CHECK	WHAT TO DO
Display will not light.	Power supply to vender.	Check for power at outlet.	Supply power to outlet.
		Check outlet circuit breaker or fuse.	Replace fuse or turn circuit breaker on.
	Power supply to cabinet control board.	Check power going to transformer.	Repair or replace damaged or bad parts.
		Check power going from transformer to board.	Repair or replace damaged or bad parts.
		Check 1.6 amp primary power fuse.	Replace fuse if bad.
	Display board interface harness to door control board.	Check harness is plugged in.	Plug in harness.
		Check harness for backed out or cut wires.	Repair or replace damaged or bad parts.
		Check harnessing from door control board to cabinet control board.	Repair or replace damaged or bad parts.
	Display.	Check display operation in diagnostics.	Replace display.
	Cabinet Control Board.	Check harnessing to and from cabinet control board.	Repair or replace damaged or bad parts.
Replace cabinet control board.			
Display does not show vend price, but decimal is lit.	Vender set for multi-price.	Prices in "S-P" and prices in "S-P2".	Set all prices in "S-P" the same and all prices in "S-P2" the same.
Flashing decimal point.	There is a recognized failure in the system.	Go to diagnostics and test all functions.	Repair or replace diagnosed failed parts.
	Cabinet Control Board.	Check harnessing to and from cabinet control board.	Repair or replace damaged or bad parts. Replace cabinet control board.
In "SP" display shows \$1 and then increases in \$1 increments.	"nF" (note factor) set incorrectly.	"nF" set to 100.	Set "nF" to 100.
	"bILL" (bills only) is turned on.	"bILL" set to "bILLS nO".	Set "bILL" to "bILLS nO".
	Cabinet Control Board.	Check harnessing to and from cabinet control board.	Repair or replace damaged or bad parts. Replace cabinet control board.
Cannot set a price on a given selection.	Select panel harness to door control harness.	Check harness for backed out or cut wires.	Repair or replace damaged or bad parts.
		Check harnessing from door control board to cabinet control board.	Repair or replace damaged or bad parts.
	Select Switch.	Select switch for proper function.	Replace switch.
	Cabinet Control Board.	Check harnessing to and from cabinet control board.	Repair or replace damaged or bad parts
Replace cabinet control board.			
Display shows "LOC".	"LOC" set via DEX Interrogation.	----	Can only be turned off via DEX interrogation or hand-held.

<b>SYMPTOM</b>	<b>POSSIBLE CAUSE</b>	<b>THINGS TO CHECK</b>	<b>WHAT TO DO</b>
Vender changes a set price to *.10 cents on its own. *.10 cents could be any value)	Secondary pricing set.	Go to "S-P2" and check if on.	Disable "S-P2".
	Select panel harness to door control board.	Check harness for backed out or cut wires.	Repair or replace damaged or bad parts.
		Check harnessing from door control board to cabinet control board.	Repair or replace damaged or bad parts.
	Cabinet Control Board.	Check harnessing to and from cabinet control board.	Repair or replace damaged or bad parts. Replace cabinet control board.
Control board loses memory when power is shut off to vender.	Cabinet Control Board.	----	Replace cabinet control board.
Display continuously scrolls "uAlt".	Cabinet Control Board.	Check harness for backed out or cut wires.	Repair or replace damaged or bad parts. Replace cabinet control board.
Scrolling "1-1" on display.	Select panel harness to door control board.	Check harness plugged to door control board.	Plug in.
		Check harness for backed out or cut wires.	Repair or replace damaged or bad parts.
	Door control board.	Check harness from select buttons to door control board.	Repair or replace damaged or bad parts.
	Cabinet Control Board.	Check harness from door control board to cabinet control board.	Repair or replace damaged or bad parts Replace cabinet control board.
Menu Lock-Up.	---	---	Power down vender. Power vender back up. Cycle the door switch. "StS InIT" will scroll across the display. Press select button 1 to reinitialize. You should now be able to access the menu.
Scrolling "Not In Service".	Vend Sensor	Check vend sensor harness.	Repair or replace bad parts.
		Vend sensor alignment.	Align vend sensors. Replace bad parts.
	Row Harness.	Check row harness for bare, cut, or mashed wires.	Repair or replace bad parts.
Stack / Cabinet Communication Harness.	Check row harness for bare, cut, or mashed wires.	Repair or replace bad parts.	

## REFRIGERATION

Symptom: **PRODUCT HOT**

Possible Cause: **Compressor will not run.**

WHAT TO CHECK	SOLUTION
1. Is the vender plugged in?	<b>1. YES</b> , see step 2. <b>NO</b> , plug it in.
2. Is the compressor power cord plugged in?	<b>2. YES</b> , see step 3. <b>NO</b> , plug it in.
3. Is the temperature control on?	<b>3. YES</b> , see step 4. <b>NO</b> , turn it on.
4. Is the circuit breaker or fuse correct?	<b>4. YES</b> , see step 5. <b>NO</b> , replace or reset.
5. Is there power at the wall outlet?	<b>5. YES</b> , see step 6. <b>NO</b> , consult an electrician.
6. Is the vender power cord good?	<b>6. YES</b> , see step 7. <b>NO</b> , replace.
7. Is the compressor power cord good?	<b>7. YES</b> , see step 8. <b>NO</b> , replace.
8. Is the temperature control bulb located properly?	<b>8. YES</b> , see step 9. <b>NO</b> , correct.
9. Is the temperature control operational?	<b>9. YES</b> , see step 10. <b>NO</b> , replace.
10. Is the thermal overload operational?	<b>10. YES</b> , see step 11. <b>NO</b> , replace.
11. Is the start relay operational?	<b>11. YES</b> , see step 12. <b>NO</b> , replace.
12. Is the compressor operational?	<b>12. YES</b> , see step 13. <b>NO</b> , replace.
13. If all of the above steps fail....	<b>13.</b> Consult the Dixie-Narco Factory Service. 1-800-688-9090. Note: Have the vender model and serial number available.

Symptom: **PRODUCT HOT**

Possible Cause: **Compressor starts but will not keep running.**

WHAT TO CHECK	SOLUTION
1. Is the temperature control knob set on its highest setting?	<b>1. YES</b> , see step 2. <b>NO</b> , adjust the knob to a higher setting.
2. Domestically, is the voltage supply within +/- 10% of rating on serial plate?	<b>2. YES</b> , see step 3. <b>NO</b> , consult the power company.
3. Is the condenser clear of obstruction?	<b>3. YES</b> , see step 4. <b>NO</b> , clear or clean.
4. Is the condenser fan blade turning?	<b>4. YES</b> , see step 5. <b>NO</b> , free the obstruction or replace the blade if needed.
5. Is the condenser fan motor operational?	<b>5. YES</b> , see step 6. <b>NO</b> , replace.
6. Is the temperature control operational?	<b>6. YES</b> , see step 7. <b>NO</b> , replace.
7. Is the tube from the compressor to condenser free of kinks?	<b>7. YES</b> , see step 8. <b>NO</b> , repair or replace.
8. Is the capillary tube free of kinks?	<b>8. YES</b> , see step 9. <b>NO</b> , replace.
9. Is the thermal overload operational?	<b>9. YES</b> , see step 10 <b>NO</b> , replace.
10. Is the start relay operational?	<b>10. YES</b> , see step 11. <b>NO</b> , replace.
11. If all of the above steps fail....	11. Consult the Dixie-Narco Factory Service 1-800-688-9090. Note: Have the vender Model & Serial number available.

Symptom: **PRODUCT HOT**

Possible Cause: **MISCELLANEOUS**

WHAT TO CHECK	SOLUTION
1. Is the evaporator fan motor working?	1. <b>YES</b> , see step 2. <b>NO</b> , replace motor.
2. Has the refrigeration system lost its charge?	2. <b>YES</b> , replace the refrigeration system <b>NO</b> , see step 3.
3. If all of the above steps fail...	3. Consult the Dixie-Narco Factory Service 1-800-688-9090. Note: Have the vender model and serial number available.

Symptom: **PRODUCT COLD BUT NOT COLD ENOUGH**

Possible Cause: **Compressor runs but won't cool product.**

WHAT TO CHECK	SOLUTION
1. Is the temperature control knob set properly?	<b>1. YES</b> , see step 2. <b>NO</b> , set properly.
2. Domestically, is the voltage supply between 103V and 127V?	<b>2. YES</b> , see step 3. <b>NO</b> , call power company.
3. Is the temperature control probe located properly?	<b>3. YES</b> , see step 4. <b>NO</b> , correct.
4. Is the condenser clear of obstruction?	<b>4. YES</b> , see step 5. <b>NO</b> , clear, clean, or space the vender.
5. Is the evaporator fan free of obstruction?	<b>5. YES</b> , see step 6. <b>NO</b> , free any obstruction or replace.
6. Is the condenser fan free of obstruction?	<b>6. YES</b> , see step 7. <b>NO</b> , free any obstruction or replace.
7. Is the evaporator free of ice?	<b>7. YES</b> , see step 8. <b>NO</b> , defrost & check the following: gasket seal, port door seal, refrigerant charge.
8. Is the temperature control operational?	<b>8. YES</b> , see step 9. <b>NO</b> , replace.
9. Is the evaporator fan operational?	<b>9. YES</b> , see step 10. <b>NO</b> , replace.
10. Is the condenser fan motor operational?	<b>10. YES</b> , see step 11. <b>NO</b> , replace.
11. Is the refrigerant tubing free of kinks?	<b>11. YES</b> , see step 12. <b>NO</b> , repair or replace.
12. Is the overload operational?	<b>12. YES</b> , see step 13. <b>NO</b> , replace.
13. Is the start relay operational?	<b>13. YES</b> , see step 14. <b>NO</b> , replace.
14. Is there refrigerant in the system?	<b>14. YES</b> , see step 15. <b>NO</b> , charge system and check for leaks.
15. If all of the above steps fail...	15. Consult the Dixie-Narco Factory Service. 1-800-688-9090. Note: Have the vender model and serial number available.



Symptom: **PRODUCT TOO COLD OR FROZEN**

Possible Cause: **Compressor runs too long or continuously.**

WHAT TO CHECK	SOLUTION
1. Is the temperature control knob set properly?	<b>1. YES</b> , see step 2. <b>NO</b> , set properly.
2. Is the temperature control bulb located properly?	<b>2. YES</b> , see step 3. <b>NO</b> , correct.
3. Is the temperature control operational?	<b>3. YES</b> , see step 4. <b>NO</b> , replace.
4. Does the evaporator frost over completely while the system is running?	<b>4. YES</b> , see step 5. <b>NO</b> , check for leaks or a low charge.
5. If all of the above steps fail.....	5. Consult the Dixie-Narco Factory Service. 1-800-688-9090. Note: Have the vender model and serial number available.

Symptom: **NOISY REFRIGERATION UNIT**

POSSIBLE CAUSES	SOLUTION
1. Are refrigerant lines free of contact with surfaces?	<b>1. YES</b> , see step 2. <b>NO</b> , correct.
2. Is the condenser fan blade obstructed or damaged?	<b>2. NO</b> , see step 3. <b>YES</b> , free any obstructions or replace the blade if needed.
3. Is the evaporator fan blade obstructed or damaged?	<b>3. NO</b> , see step 4. <b>YES</b> , free any obstructions or replace the blade if needed.
4. Is compressor noisy?	<b>4. NO</b> , see step 5. <b>YES</b> , replace.
5. If all of the above steps fail....	5. Consult the Dixie-Narco Factory Service 1-800-688-9090. Note: Have the vender Model & Serial number available..

Symptom: **EXCESSIVE CONDENSATE**

WHAT TO CHECK	SOLUTION
<p>1. Is the door sealed properly? (This can be checked by inserting a piece of paper, thin plastic or paper currency between the cabinet and the door seal when the main door is open. When the door is closed properly, the paper should exert some resistance as it is pulled out.</p>	<p>1. <b>YES</b>, see step 4.  <b>NO</b>, Ensure the door is closed tightly. If door still does not seal properly, see step 2.</p>
<p>2. Is the motor cover interfering with the inner door?</p>	<p>2. <b>YES</b>, reinstall motor cover properly.  <b>NO</b>, see step 3.</p>
<p>3. Has the machine been vandalized?</p>	<p>3. <b>YES</b>, replace necessary components.  <b>NO</b>, see step 4.</p>
<p>4. Are soakers positioned properly?</p>	<p>4. <b>YES</b>, see step 5.  <b>NO</b>, place soakers upright in pan so that air will flow over &amp; through the soakers.</p>
<p>5. Are there 14 fiberglass soakers in the pan?</p>	<p>5. <b>YES</b>, see step 6.  <b>NO</b>, place 14 fiberglass soakers in the condensate pan.</p>
<p>6. Are the condenser &amp; evaporator free from obstruction?</p>	<p>6. <b>YES</b>, see step 7.  <b>NO</b>, remove all debris and/or cans from the area around the evaporator and condenser. Clean the evaporator &amp; condenser coils with a stiff brush or compressed air.</p>
<p>7. Is the delivery door misaligned?</p>	<p>7. <b>YES</b>,  A. Level the vender properly.  B. Align the inner &amp; outer doors so that the delivery door does not stick open.  <b>NO</b>, see step 8.</p>
<p>8. If all of the above steps fail...</p>	<p>8. Consult the Dixie-Narco Factory Service 1-800-6888-9090.  Note: Have the vender model and serial number available.</p>

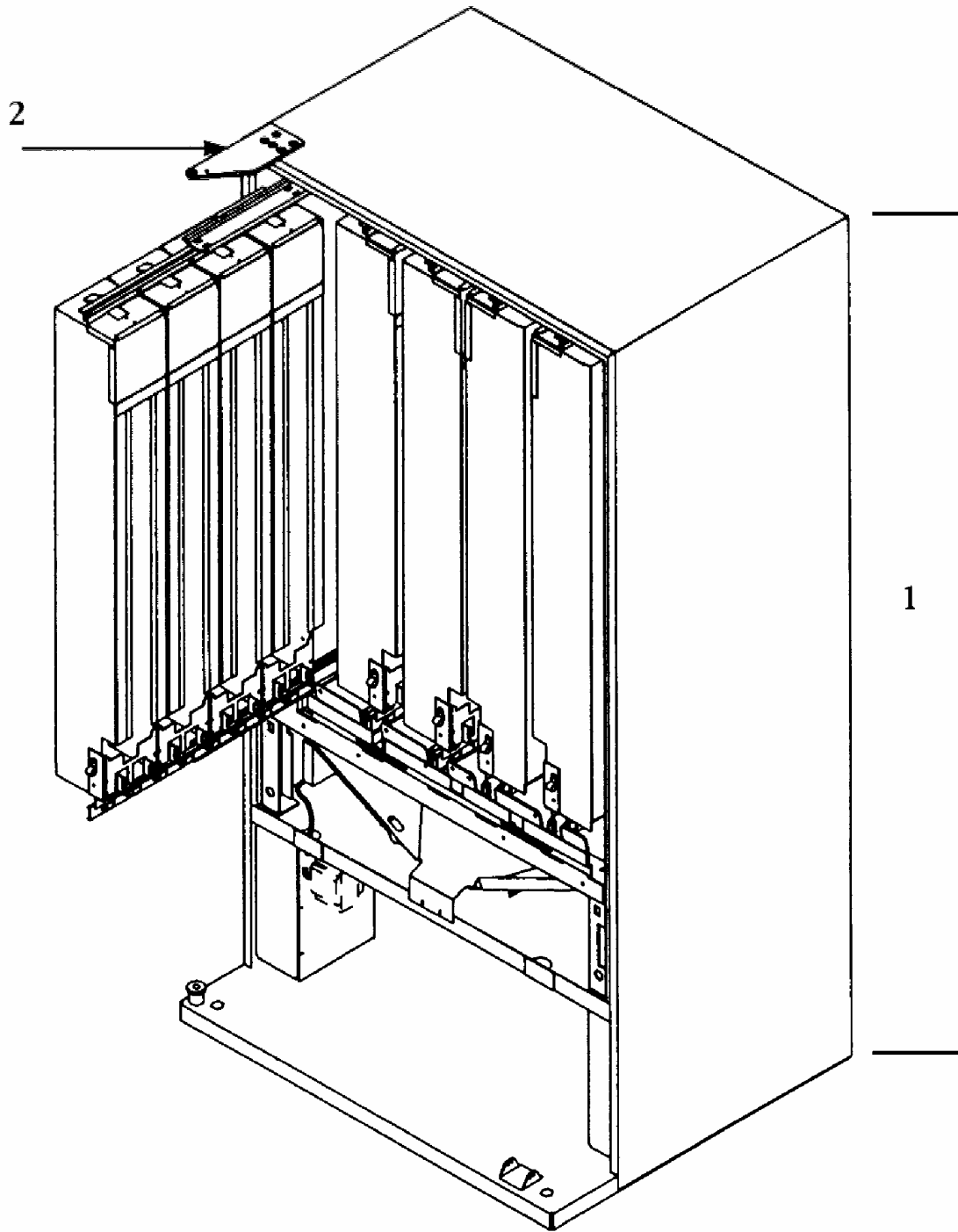

## FLEXPAK™ 3000 CABINET

Item	Part Number	Description
1		Assembly, Foam Cabinet
	594,060,300.03	Wide DMV 72"
	596,060,000.03	Narrow DMV 72"
	not available at print	Wide DMV 79"
2		Door Hinge
2a	801,304,670.01	Flanged Top, All Models w/out Extended or Piano Hinge
2b	801,303,730.31	Top, All Models w/out Extended or Piano Hinge
2c		Assy., Top Extended
	801,304,170.11	494-6258 to 500-6258
2d	801,304,540.11	All others w/ Extended Hinge
	801,304,180.01	494-6258 to 500-6258
	801,304,370.01	001-4074 to 010-4074 and 001-6259 to 0175-6259
	801,304,480.01	0156-6259 to 0175-6259
	801,304,450.01	6269 and higher
2e		Assy., Bottom Cabinet Hinge Extended
	801,304,230.01	494-6258 to 500-6258
	801,304,320.11	0001-4074 to 010-4074 and 001-6259 to 0175-6259 and 0156-6259 to 0175-6259
	801,304,420.01	6269 and higher
2f	801,304,640.21	Piano Hinge
3		Loading Rack Weld Assembly (0001-6259 & higher)
	803,200,330.51	All Wide Models
	803,200,300.11	All Narrow Models
4		Loading Rack Pivot Bracket (0001-6259 & higher)
	594,070,550.03	All Models
5		Loading Rack Support (0001-6259 & higher)
	594,070,540.03	All Models
6		Clevis Pin Assembly (Runs 6208, 6244, & 6246)
	594,010,000.04	All Single Point (1/4 turn) locking Flex-Paks (Runs 6208, 6244, 6246)
7A		Cabinet Stiffener Front Plate
	594,040,260.13	All Wide Models
	596,040,040.23	All Narrow Models
7B		Edge Protector, Front Cabinet Stiffener
	801,809,460.11	All Models
7C		Caterpillar Grommeting
	801,809,930.01	All Models
7D		Kydex Door
	801,903,340.01	All Models
8A		Ingress Guards
	594,040,270.23	All Wide Models
	596,040,050.13	All Narrow Models
8B		Ingress Guard Cover
	594,040,340.03	All Models
9		Vandal Panel Left Side
	594,020,140.13	Extended Hinge 72" DMV's (66.734")
	165,000,031.43	Standard Hinge 72" DMV's (68 1/8")
	not available at print	Extended Hinge 79" DMV's
	164,000,031.63	Standard Hinge 79" DMV's (75 5/8")

<b>Item</b>	<b>Part Number</b>	<b>Description</b>
10		Vend Sensor Bracket
	594,000,020.33	All Wide Models
11		Rear Condensation Plate
	594,000,050.03	All Wide Models
		All Narrow Models
	901,201,780.01	Pop Rivet 1/4" (13) [Piano Hinge]
	900,303,120.01	Carriage Bolt 1/4-20x5/8 Grd 5 (2) [Piano Hinge]
	900,800,670.01	Keys Nut 1/4-20 (2) [Piano Hinge]
	801,903,110.01	Hole Plug .750 Dia. [Piano Hinge] (2)
	803,301,020.01	Bolt Insulator [Piano Hinge] (2)

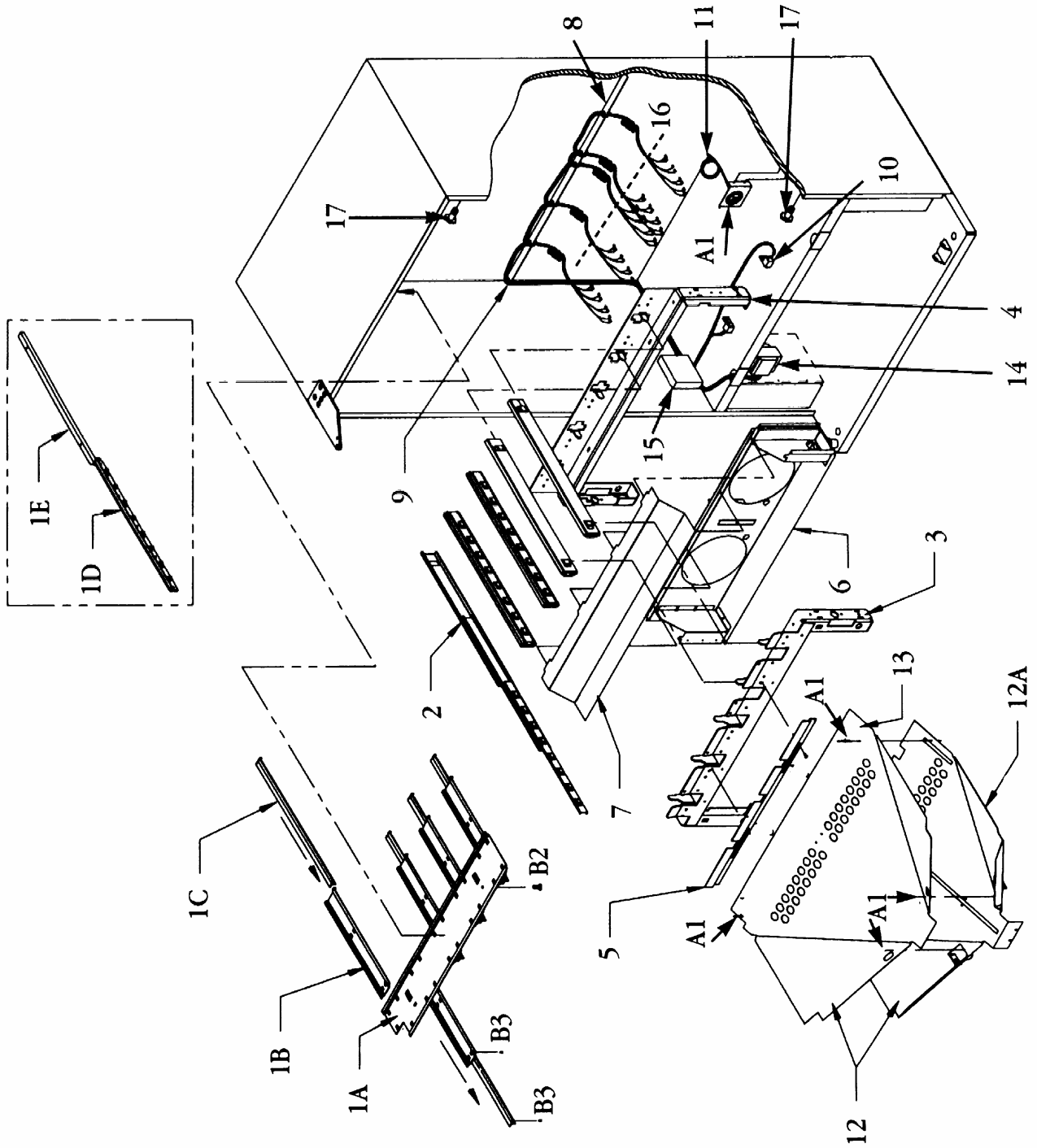

## FLEXPAK™ 3000 CABINET INTERIOR

Item	Part Number	Description
1A		DMV Top Slide Base, Bracket (0001-6259 & higher)
	594,070,280.03	Wide DMV 72" & 79"
	596,070,050.03	Narrow DMV 72"
1B		DMV Top Slide Center Bracket (0001-6259 & higher)
	594,070,290.03	All Models
1C		DMV Top Slide Outer Bracket (0001-6259 & higher)
	594,070,310.03	All Models
1D		Top Slide (Prior to 0001-6259)
	594,070,390.03	Left Wide DMV 72", 3 per
	594,070,410.03	Right Wide DMV 72", 2 per
1E		Top Guide (Prior to 0001-6259)
	594,070,370.03	Left Wide DMV 72", 3 per
	594,070,360.03	Right Wide DMV 72", 2 per
2		DMV Bottom Module Slide
	801,514,220.01	All Models
3		DMV Front Support Weld Assembly
	594,070,600.03	All Wide Models
	596,070,200.03	All Narrow Models
4		DMV Rear Support Weld Assembly
	594,070,700.03	All Wide Models
	596,070,300.03	All Narrow Models
5		Module Retaining Bracket
	594,070,320.23	All Wide Modules (27.745"x4.496") - cleared for loading rack (0001-6269 & higher)
	594,040,090.03	All Wide Modules (27.495"x2.279") (prior to 0001-6269)
	596,070,090.23	All Narrow Modules
6		Evaporator Fan Shroud
	594,040,020.23	All Wide Models (dual tank mount fans, front flow) (Prior to 0001-6309, Includes run 6311)
	594,040,160.03	All Wide Models (dual bracket mount fans, rear flow) (0001-6323 & higher, exceptions: 6324, 6339, 6340)
	596,040,010.23	All Narrow Models (bracket mount) (0000-6309 & higher, except run 6311)
7		Evaporator Cover
	594,040,070.33	All Wide Models (dual tank mount fans) (Prior to 0001-6309, Includes 6311)
	594,040,180.13	All Wide Models (dual bracket mount fans) (0001-6309 & higher, except run 6311)
	596,040,020.33	All Narrow Models (bracket mount) (0001-6309 & higher, except run 6311)
8		Rear Plug Mounting Bracket
	594,070,530.03	All Wide Models w/ Coiled Harness 804,909,880.61
	594,070,530.33	All Wide Models w/ Coiled Harness 804,910,740.01
	596,070,110.03	All Narrow Models w/ Coiled Harness 804,909,880.61
	596,070,110.13	All Narrow Models w/ Coiled Harness 804,910,740.01
9A		Plug Bar Harness
	804,910,740.21	Rear Mount to DeAmertek (latching connector w coiled row harness) (0001-6259 & higher)
	804,909,880.61	Rear Mount to Ardac (floating connector w/ coiled row harness) (0001-6259 & higher)
	804,910,170.01	Front Mount to Ardac (run 6244 only)
	804,910,180.01	Front Mount to Ardac (used w/ DMV w/ modified SII Controller mounted on door)
9B		Stack / Cabinet Controller Harness
	804,910,050.21	Ardac (from cabinet controller to vend sensor/door board)
	804,912,020.11	DeAmertek (from cabinet controller to D/D board)



Item	Part Number	Description	
10A		Vend Sensor	
	804,910,910.21	All Models w/ Cutler Hammer Sensor to DeAmertek Board	
	804,910,060.21	All Models w/ Cutler Hammer Sensor to Ardac Board	
	804,909,870.11	All Models w/ Banner Sensor (Runs 6204, 6208, & mixed on 6244)	
10B		Control Board to Banner Sensor Harness (Runs 6204, 6208, & mixed on 6244)	
	804,909,860.01	All Models w/ Banner Sensor	
10C		Banner Vend Sensor Extension Harness (Runs 6204, 6208, & mixed on 6244)	
	804,909,900.01	All Models w/ Banner Sensor	
11		Temperature Control	
	802,800,490.01	All Models, front flow	
	802,800,500.21	All Models, rear flow DMV72N 6310 & up DMV72W & 79W 6323 & up	
12		Vend Chute Assembly	
	594,070,500.13	All Wide Models	
	596,070,xxx.03	Narrow Models, Center	
	596,070,400.03	Narrow Models, Off Center	
12a		Vend Chute	
	594,000,040.03	All Wide, Wide Mouth (large port)	
	594,000,010.23	All Wide Models (use with Cutler Hammer Vend Sensor)	
	596,000,010.03	Narrow Center Models (use with Cutler Hammer Vend Sensor)	
	596,000,020.03	Narrow Off-Center	
	604,050,310.13	Delivery Large Port DP Chute	
13		Vend Chute Liner	
	801,902,880.01	Wide	
	801,902,890.01	Narrow, Center	
	801,903,060.01	Narrow, Off Center	
14		Transformer with Harness	
	804,909,930.21	All Domestic Models w/ Ardac Controllers	
	804,910,800.11	All Domestic Models w/ DeAmertek Controllers	
	804,910,950.31	All Export Models 50/60 Hz. DeAmertek Controllers	
15		Cabinet Controller	
	804,911,400.01	DeAmertek "4-button Programming" 6305 & higher. (Includes 6278-001 to 450.)	
		Exceptions: 6305-222 to 759, 6305-871 to 1170, 6307-all, 6308-all, 6311-201 to 341, 6311-1558 to 1713	
	804,910,970.01	DeAmertek "2-button Programming" 6305 & higher. (Includes 6278-001 to 450.)	
		Exceptions: 6305-222 to 759, 6305-871 to 1170, 6307-all, 6308-all, 6311-201 to 341, 6311-1558 to 1713	
	804,910,540.01	Ardac "2-button Programming"	
	804,910,130.01	Ardac "2-button Programming" w/ Banner Sensor	
16		Module Row Harness	
	804,911,020.11	Coiled with Diode (0001-6259 & higher)	
	804,910,730.11	Coiled w/out Diode (0001-6259 & higher)	
	804,909,550.41	Non-Coiled, Rear Mount (run 6208 only)	
	804,910,170.01	Front Mount	
	not available	Rear Mount Latching Connector w/ Spring Attached	
	804,910,180.01	Front Mount w/ SII Style Door Controller (Service Only)	
17		Two Point Lock Latch Strike (Cabinet)	
	A	594,070,730.63	w/ Dog Ear (0001-6259 & higher)
	B	900,400,460.01	Bolt (run 6258 only)
18		Door Controller Assembly	
	804,910,120.01	7 Segment Ardac	
	804,911,030.01	14 Segment Ardac (6269-849 to 902 and 949 to 998)	
	804,910,990.01	14 Segment D/D Board DeAmertek 6305 & higher. (includes 6278-001 to 450)	

		Exceptions: 6305-222 to 759, 6305-871 to 1170, 6307- all, 6308 - all, 6311-201 to 341, 6311-1558 to 1713
--	--	---

Item	Part Number	Description
19		Display Board Assembly
	804,910,100.31	VRV 7 Segment
	804,910,110.01	Non VRV 7 Segment
	804,910,940.11	14 Segment Ardac (6269-849 to 902 and 949 to 998)
	804,910,990.21	14 Segment D/D Board DeAmertek (also listed in item 18)
20A		Evaporator Fan Motor Assembly - Tank Mount Front Flow (prior to 0001-6309, including 6311, exception 6306)
	594,040,500.03	115V Domestic Models
	594,040,600.03	220-240/50 Export Models
20B		Evaporator Fan Motor Assembly - Bracket Mount Front Flow (runs 6306 & 6309 only)
	594,040,700.13	115V Domestic Models 6W
	594,041,000.03	220V Export Models 6W
20C		Evaporator Fan Motor Assembly - Bracket Mount Rear Flow (0001-6323 & higher, exceptions 6324, 6339, & 6340)
	594,041,100.03	115V Domestic Models 9W
	594,041,200.03	220V Export Models 9W
21A		Bracket Evaporator Fan Motor - Tank Mount (prior to 0001-6309, includes 6311, exception 6306)
	164,040,080.03	All Models Tank Mount Front Flow
21B		Bracket, Evaporator Fan Motor - Bracket Mount (0001-6309 & higher, includes 6311)
	594,040,320.13	6W Front Flow
	594,040,170.33	9W GE Front Flow
	594,040,290.23	9W Morrill Rear Flow
22		Evaporator Fan Motor
	804,500,590.21	115V 6W
	804,501,010.01	115V 9W
	804,500,520.21	220-240/50 6W
	804,501,030.01	220-240/50 9W
23		Evaporator Fan Blade
	801,304,090.11	Front Flow (7.75 CCW32UBG)
	801,304,500.01	Rear Flow (FV800CW40S) (0001-6323 & higher, includes 6310)
24		1/3 HP Refrigeration Kit
	594,040,400.04	1202C-E Domestic Models
	560,241,100.13	1222-E IEC Export 220-240/50 System (kit # not available at print)
	560,241,300.13	1222-E AUS Export 220/50 System (kit # not available at print)
	560,241,500.33	1222-E GEN Export 220/50 System (kit # not available at print)
25		Wiring Diagrams
	803,843,680.11	Domestic DeAmertek
	803,843,630.01	Export DeAmertek
	803,848,030.21	Ardac
	803,849,080.11	Ardac Front Stack Harness
26		Diode Assembly
	804,910,630.01	Rear Mount Row Harness (0001-6259 & higher)
	801,902,480.01	Delrin Washer
	901,100,610.11	Pop Rivet, 1/8
	900,500,261.11	Screw, Shoulder
	900,301,730.21	Screw, Tap Type F 1/4-20x1"
	900,301,560.01	Screw, Phil Pan Swage Form #8-32x3/8
900,800,510.01	Elastic Stop Nut, #8-32 (used on shoulder screws)	

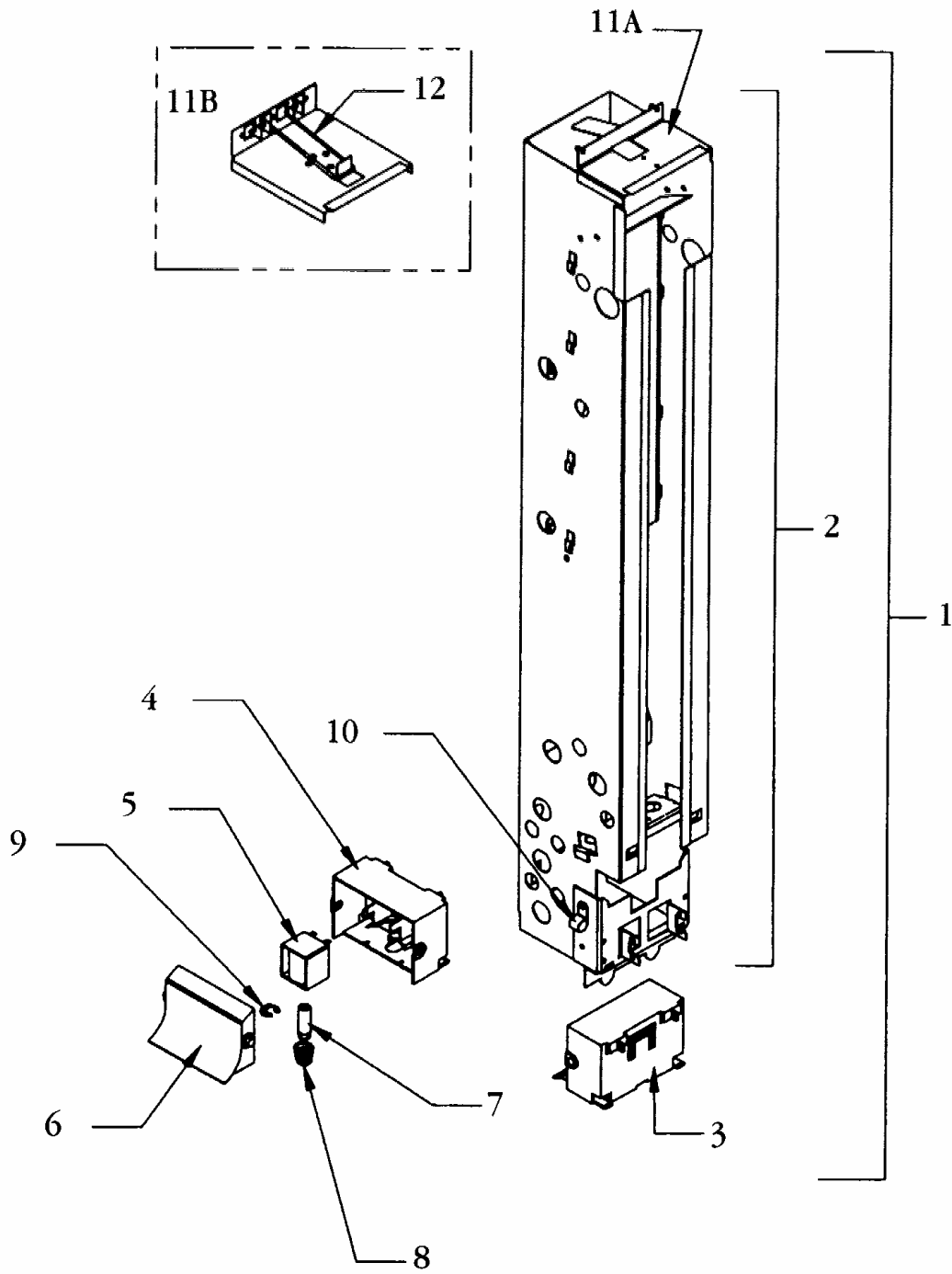

## FLEXPAK™ 3000

### 12 oz. CAN MODULE

Item	Part Number	Description
1		Vend Module Assembly (with vend mechanism)
	594,070,900.03	12 oz. Can Module, Plastic Top Cap w/ spring clip, 72" Models
	594,070,300.03	12 oz. Can Module, Metal Top Cap w/ wire clip, 72" Models
	594,072,400.03	20 oz. Bottle Module, Plastic Top Cap with Divider & Spring Clip, 72" Models
2		Module Assembly (without vend mechanism)
	594,070,800.03	12 oz. Can Module, Plastic Top Cap w/ spring clip, 72" Models
	594,070,200.03	12 oz. Can Module, Metal Top Cap w/wire clip -72" Models
	594,072,500.03	20 oz. Bottle Module, Plastic Top Cap w/ divider and spring clip, 72" Models
3		Vend Mechanism Assembly
	801,808,760.11	Plastic, All Models (0001-6246 & higher)
	not available	Metal, All Models (serialized 0001-6204 to 0303-6244)
		Replace module assy. with 594,070,300.03
4		Vend Mechanism Bracket
	801,808,770.01	Plastic, All Models (0001-6246 & higher)
	not available	Metal (0001-6204 to 0303-6244)
5		Vend Mechanism Solenoid
	804,300,140.01	All Models
6		Vend Mechanism Platform
	801,808,810.01	Plastic, All Models (0001-6246 & higher)
	not available	Metal (0001-6204 to 0303-6244)
7		Vend Mechanism Plunger
	800,502,800.01	Plastic, All Models (0001-6246 & higher)
	not available	Metal (0001-6204 to 0303-6244)
8		Vend Mechanism Spring
	801,700,920.01	All Models
9		Vend Mechanism Plunger E Ring
	901,503,070.01	All Models
10A		Clamp 1", Heyco 3390
	901,901,890.01	Used for Service Only
10B		Rubber Grommet; .750" ID, 1.370"OD
	902,001,200.01	Used for Service Only
11		Module Top Cap
	801,808,800.01	20 oz. Plastic Snaps in Place (spring clip)
	A 801,808,780.01	12 oz. Plastic Snaps in Place (spring clip)
	B 594,070,330.03	12 oz. Metal Welded in Place (wire clip)
12		Top Cap Latch
	A 901,700,950.01	Spring Clip, for Plastic Top Cap
	B 801,401,600.01	Wire Clip, for Metal Top Cap 12 oz. Cans
	B 801,401,610.01	Wire Clip, for Metal Top Cap 20 oz. Bottle Module
13		Cover, Module Row Harness
	801,809,560.11	12 oz. Modules
	801,809,550.21	Adjustable Modules (20 oz.)
	901,100,530.01	Pop Rivet, 1/8"
	901,100,600.01	Pop Rivet, 3/16"

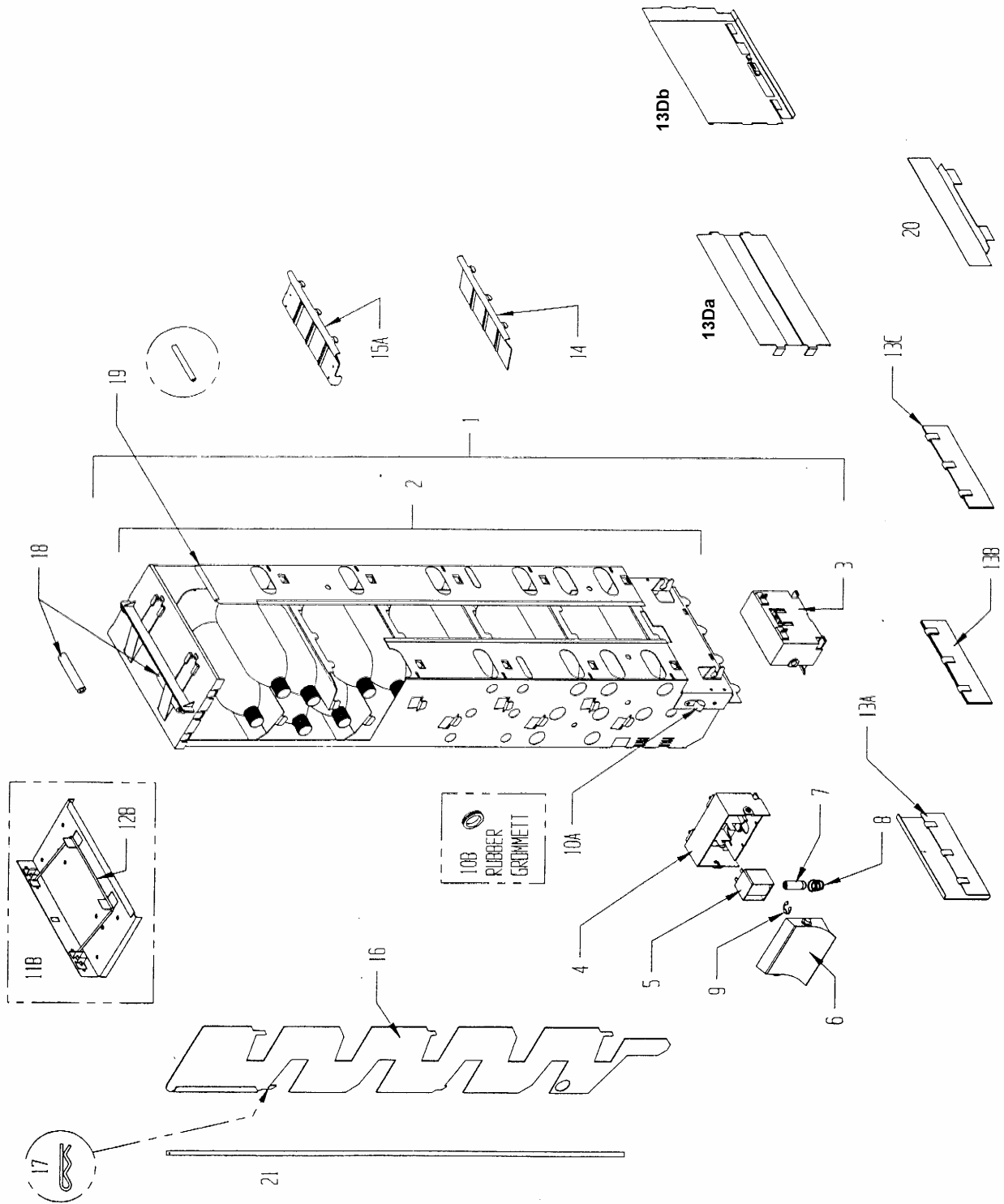

## FLEXPAK™ 3000

### 16 oz. / 20 oz. BOTTLE MODULES

Item	Part Number	Description
1		Vend Module Assembly (with vend mechanism)
	594,073,100.03	20 oz. Bottle Module, Plastic Top Cap w/ divider, spring clip, ramp covers & wire guards, 72" Models
	594,071,800.03	20 oz. Bottle Module, Plastic Top Cap w/ spring clip, 72" Models
	594,072,400.03	20 oz. Bottle Module, Plastic Top Cap with divider & spring clip, 72" Models
	594,071,700.03	20 oz. Bottle Module, Metal Top Cap w/ wire clip, 72" Models
	594,071,400.03	16 oz. Bottle Module, Plastic Top Cap w/ spring clip, 72" Models
	594,071,300.03	16 oz. Bottle Module, Metal Top Cap w/ wire clip, 72" Models
2		Module Assembly (without vend mechanism)
	594,071,600.03	20 oz. Bottle Module, Plastic Top w/ spring clip, 72" Models
	594,071,500.03	20 oz. Bottle Module, Metal Top Cap w/ wire clip, 72" Models
	594,072,500.03	20 oz. Bottle Module, Plastic Top Cap w/ divider and spring clip, 72" Models
	594,071,200.03	16 oz. Bottle Module, Plastic Top Cap w/ spring clip, 72" Models
	594,071,100.03	16 oz. Bottle Module, Metal Top Cap w/ wire clip, 72" Models
3		Vend Mechanism Assembly
	801,808,760.11	Plastic, All Models (0001-6246 & higher)
	not available	Metal, All Models (serialized 0001-6204 to 0303-6244)
		Replace with metal top cap module assemblies
4		Vend Mechanism Bracket
	801,808,770.01	Plastic, All Models (0001-6246 & higher)
	not available	Metal (0001-6204 to 0303-6244)
5		Vend Mechanism Solenoid
	804,300,140.01	All Models
6		Vend Mechanism Platform
	801,808,810.01	Plastic, All Models (0001-6246 & higher)
	not available	Metal (0001-6204 to 0303-6244)
7		Vend Mechanism Plunger
	800,502,800.01	Plastic, All Models (0001-6246 & higher)
	not available	Metal (0001-6204 to 0303-6244)
8		Vend Mechanism Spring
	801,700,920.01	All Models
9		Vend Mechanism Plunger E Ring
	901,503,070.01	All Models
10A		Clamp 1", Heyco 3390
	901,901,890.01	Used for Service Only
10B		Rubber Grommet; .750" ID, 1.370" OD
	902,001,200.01	Used for Service only
11		Module Top Cap
	801,808,800.01	Plastic 20 oz. - Snaps in Place (spring clip)
	801,808,790.01	Plastic 16 oz. - Snaps in Place (spring clip)
	594,070,350.03	Metal 20 oz. - Welded in Place (wire clip)
	594,070,340.03	Metal 16 oz. - Welded in Place (wire clip)
12		Top Cap Latch
	A 901,700,950.01	Spring Clip for Plastic Top Cap
	B 801,401,610.01	Wire Clip for Metal Top Cap
13		Spacer, Module (20 oz. and 16 oz. modules) (0001-6204 to 0001-6312)
	A 594,070,790.03	.44"x3.50"x7.25"
	B 594,070,420.03	.194"x2.11"x7.25"

C	594,070,560.03	.097"x2.11"x7.25"
---	----------------	-------------------

Item	Part Number	Description
13D		Spacer, Module w/ Picket Fence (20 oz. Module) (0001-6312 & higher)
	594,070,750.43	.045"x9.625"x5.25" (tab spacer)
	594,072,600.03	Adjustable Module Spacer w/ Spring 0001-6312 to 0001-6387
	594,073,400.03	Adjustable Module Spacer w/ Spring 0001-6387 and up (bull nose)
14		Lower Ramp (1 per module)
	594,070,660.13	20 oz. Module w/tabs
	594,070,490.13	16 oz. Modules w/tabs
15 A		Upper Ramps
	594,070,670.33	20 oz. Module w/tabs
	594,070,380.03	20 oz. Module w/ pop rivets
	594,070,510.03	16 oz. Module w/ tabs
16		Center Divider
	594,070,650.33	20 oz. Modules prior to 0001-6387
	594,070,780.03	20 oz. Modules 0001-6387 and up (bull nose)
17		Hitch Pin Clip
	800,902,380.01	1 per Center Divider, 1 per module guide rail
18		Module Retainer, Top (Spring Clip)
	801,809,580.01	1 per Module
19		Edge Protector
	801,809,570.01	All Modules
20		Cover, Module Row Harness
	801,809,550.21	Adjustable Modules (20 oz.)
21		Rail, Adjustable Module Guide
	594,071,010.03	All Adjustable Modules (20 oz.), 72"
22		Wire Standoff (row harness clamp)
	801,903,170.01	Bull Nose Modules (0001-6387 and up)



## FLEXPAK™ 3000

### HARNESSES/ELECTRONIC COMPONENTS

Item	Part Number	Description
1		Plug Bar Harness (from cabinet controller to plug bar)
	804,910,740.21	DeAmertek Rear Mount (0001-6259 & higher)
	804,909,880.61	Ardac Rear Mount (0001-6259 & higher)
	804,910,170.11	Ardac Front Mount (floating connectors) (run 6244 only)
	804,910,180.01	Front Mount to Ardac (used w/ DMV w/ Modified SII Controller)
2		Stack / Cabinet Controller Harness
	804,912,020.11	DeAmertek (from cabinet controller to D/D board)
	804,910,050.21	Ardac (from cabinet controller to vend sensor/door board) (0001-6246 & higher)
3		Power Harness
	804,910,840.11	DeAmertek, Domestic
	804,910,040.11	Ardac, Domestic
	804,911,190.21	Export
4		Display Harness
	804,910,010.21	All Models
5		Door Communications Harness
	804,910,010.21	Ardac Coin Mech / Cabinet Controller Harness
	804,912,010.11	DeAmertek Door Communication
	804,912,020.11	DeAmertek Cabinet Communication
	804,911,300.01 (obsolete)	DeAmertek Communication (replaced by 804,912,010.11 & 804,912,020.01)
6		Main Wiring Harness
	804,902,220.71	Domestic
	804,910,670.01	w/out Plug, Export Long
7		Stack Extension Harness
	804,909,890.01	All Models
8		Low Level Note Acceptor Harness
	804,910,020.01	Ardac - Power Harness
	804,910,030.01	Ardac - Interface Harness (from acceptor to door controller)
	804,911,810.01	DeAmertek
9A		Module Row Harness
	804,911,020.11	Coiled, w/ Diode (0001-6259 & higher)
	804,910,730.11	Coiled, w/out Diode (0001-6259 & higher)
	804,909,550.41	Rear Mount Floating Connector (run 6208 only)
	not available	Rear Mount Latching Connector w/ Spring Attached
	804,910,170.01	Front Mount
	804,910,180.01	Front Mount w/ SII Style Door Controller (Service Only)
9B		Module Row Harness Faston Cover
	804,912,340.01	All Models
10		Door Harness
	804,910,140.21	Coke 9 Select - Ardac
	804,911,220.01	Coke 9 Select - DeAmertek
	804,910,550.11	Generic 10 Select - Ardac
	804,911,230.01	Generic / Veryfine 10 Select - DeAmertek
	804,910,150.21	Pepsi MC 10 Select - Ardac
	804,911,230.01	Pepsi MC 10 Select - DeAmertek
	804,910,160.21	Pepsi TBV 14 Select - Ardac
	804,911,240.01	Pepsi TBV 14 Select - DeAmertek
	804,910,920.11	Display 10 Select - Ardac

Item	Part Number	Description
10	804,911,800.01	Display 10 Select - DeAmertek
	804,911,530.01	Display 8 Select - DeAmertek
	804,911,270.01	Dr. Pepper D3 10 Select - DeAmertek
	804,911,280.01	Dr. Pepper V4 10 Select - DeAmertek
	804,911,290.01	7UP 10 Select - DeAmertek
	804,911,430.01	Membrane Select Panel Interface
11A		Door Switch
	804,100,770.21	All Models
11B		Door Strap
	572,050,130.63	All Models
12		Software (Eprom)
	804,911,360.01	Cabinet Controller 2-Button Programming (57x526-0)
	804,911,370.21	Cabinet Controller 4-Button Programming (57x575-0)
	804,912,090.01	Cabinet Controller 2-Button Programming Australia Only
	804,912,080.01	Cabinet Controller 4-Button Programming Australia Only
	804,911,460.01	Door Controller Ardac (57x553-0)
	804,911,440.11	Display/Door (PIC) Controller DeAmertek (57x616-1)
13		Labels
	803,845,360.01	2-Button Programming
	803,846,210.01	4-Button Programming
	803,845,370.01	Module Numbering
	803,845,380.01	Coin Mechs
	903,855,440.01	Price Label
	803,846,470.01	20 oz. Module Adjustments and Package Set-Ups
	803,843,680.11	Wiring Diagram Domestic DeAmertek
	803,848,030.21	Wiring Diagram Domestic Ardac
	803,843,630.01	Wiring Diagram Export DeAmertek
	803,849,080.11	Wiring Diagram Front Mount Ardac
	803,845,780.01	Module Content ID Strip
14		Diode Assembly
	804,910,630.01	All Models
15		Ground Lead, Main Door to Cabinet
	804,911,010.01	All Flex-Paks w/ Extended Hinges
		All Flex-Paks w/ Standard Hinges
16A		Fuse Holder Assembly, DeAmertek Only
	804,910,900.01	Domestic
	804,911,120.01	IEC (5x20mm)
16B		Fuse (DeAmertek Venders Only)
	804,912,030.01	Domestic 1.6Amp 3AG (1 1/4"long)
	804,911,130.01	IEC 25 VAC/1A (5x20mm)
16C		Fuse Holder Cable Jumper (DeAmertek Venders Only)
	804,911,840.01	18 AWG
16D		Fuses, Ardac
	804,800,710.01	1.6 Amp
	804,908,080.01	4 Amp
17		Transformer w/Harness
	804,909,930.11	All Domestic Models w/ Ardac Controllers
	804,910,800.11	All Domestic Models w/ DeAmertek Controllers
	804,910,950.31	All Export Models w/ DeAmertek Controllers
18		Sleeving, Braided Polyester for Hanging dress & protection
	804,911,330.01	All Models
19		DEX harness
	804,907,830.41	External, All Models

Item	Part Number	Description
20		Display Boards
	804,910,990.21	Door/Display DeAmertek 14 Segment 6305 & higher. (Includes 6278-001 to 450) Exceptions: 6305-222 to 759, 6305-871 to 1170, 6307-all, 6308-all, 6311-201 to 341, 6311-1558 to 1713
	804,910,940.11	Display 14 Segment Ardac (6269-847 to 902 & 949 to 998)
	804,910,110.01	Display 7 Segment Non VRV Ardac
	804,910,100.31	Display 7 Segment VRV Ardac
21		Cabinet Controllers
	804,911,400.01	DeAmertek "4-Button Programming" 6305 & higher. Includes 6278-001 to 450 Exceptions: 6305-222 to 759, 6305-871 to 1170, 6307-all, 6308-all, 6311-201 to 341, 6311-1558 to 1713
	804,910,970.01	DeAmertek "2-Button Programming" 6305 & higher. Includes 6278-001 to 450 Exceptions: 6305-222 to 759, 6305-871 to 1170, 6307-all, 6308-all, 6311-201 to 341, 6311-1558 to 1713
	804,910,540.01	Ardac "2-Button Programming"
	804,910,130.01	Replaced by 804,910,540.01
22		Door Controller Assembly
	804,910,120.01	7-Segment Ardac
	804,911,030.01	14-Segment Ardac (6269-847 to 902 and 949 to 998)
	804,910,990.21	14 Segment D/D Board DeAmertek 6305 & higher. Includes 6278-001 to 450 Exceptions: 6305-222 to 759, 6305-871 to 1170, 6307-all, 6308-all, 6311-201 to 341, 6311-1558 to 1713
23		Vend Sensor
	804,910,910.21	All Models w/ Cutler Hammer Sensor to DeAmertek Board
	804,910,060.21	All Models w/ Cutler Hammer Sensor to Ardac Board
	804,909,870.01	All Models w/ Banner Sensor

# Sample Wiring Diagram

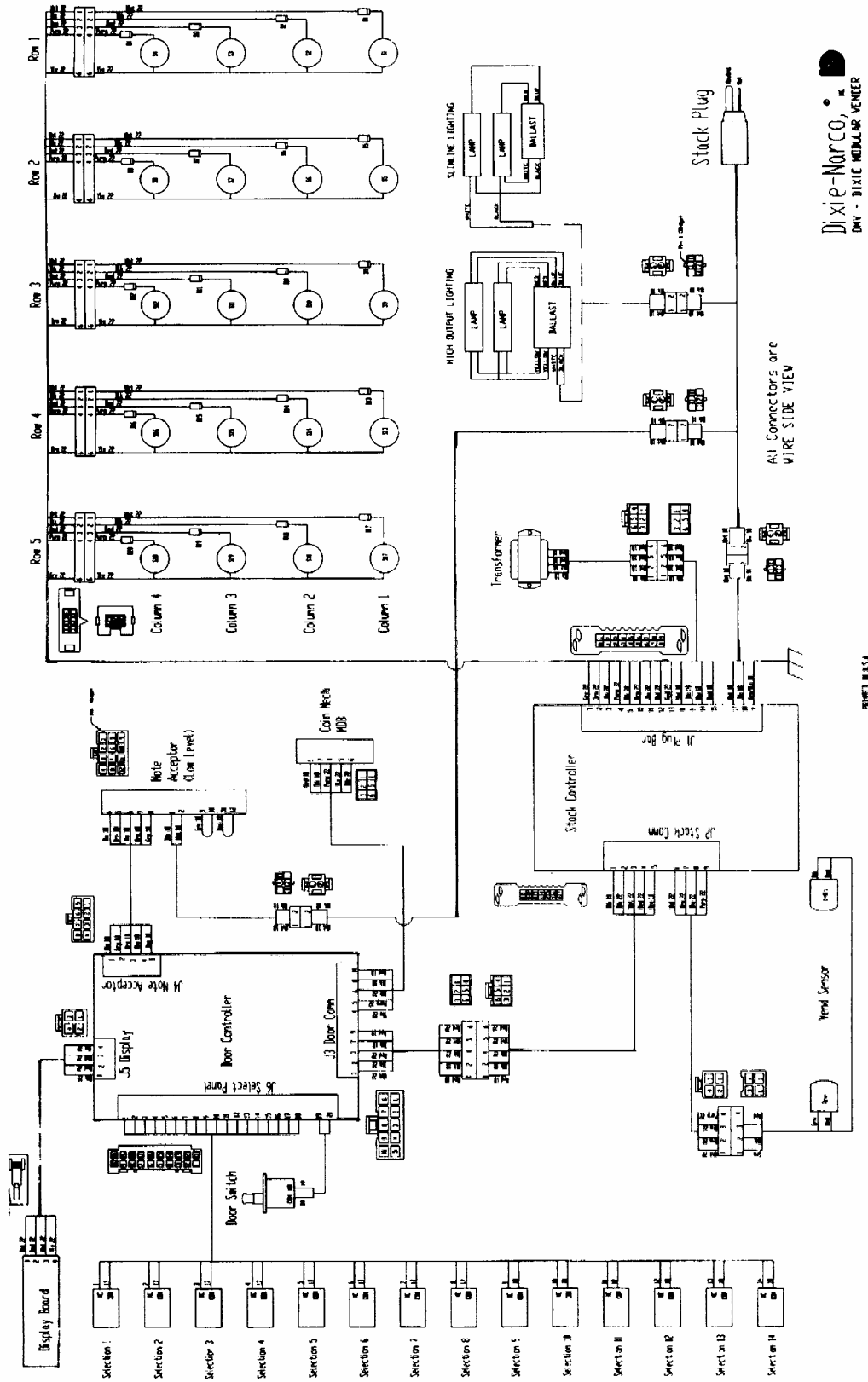

Dixie-Narco, Inc.  
DNY - DIXIE MEDICAL VENDOR

# Flex-Pak™ 3000 Ardac Controllers

## Door

## Cabinet

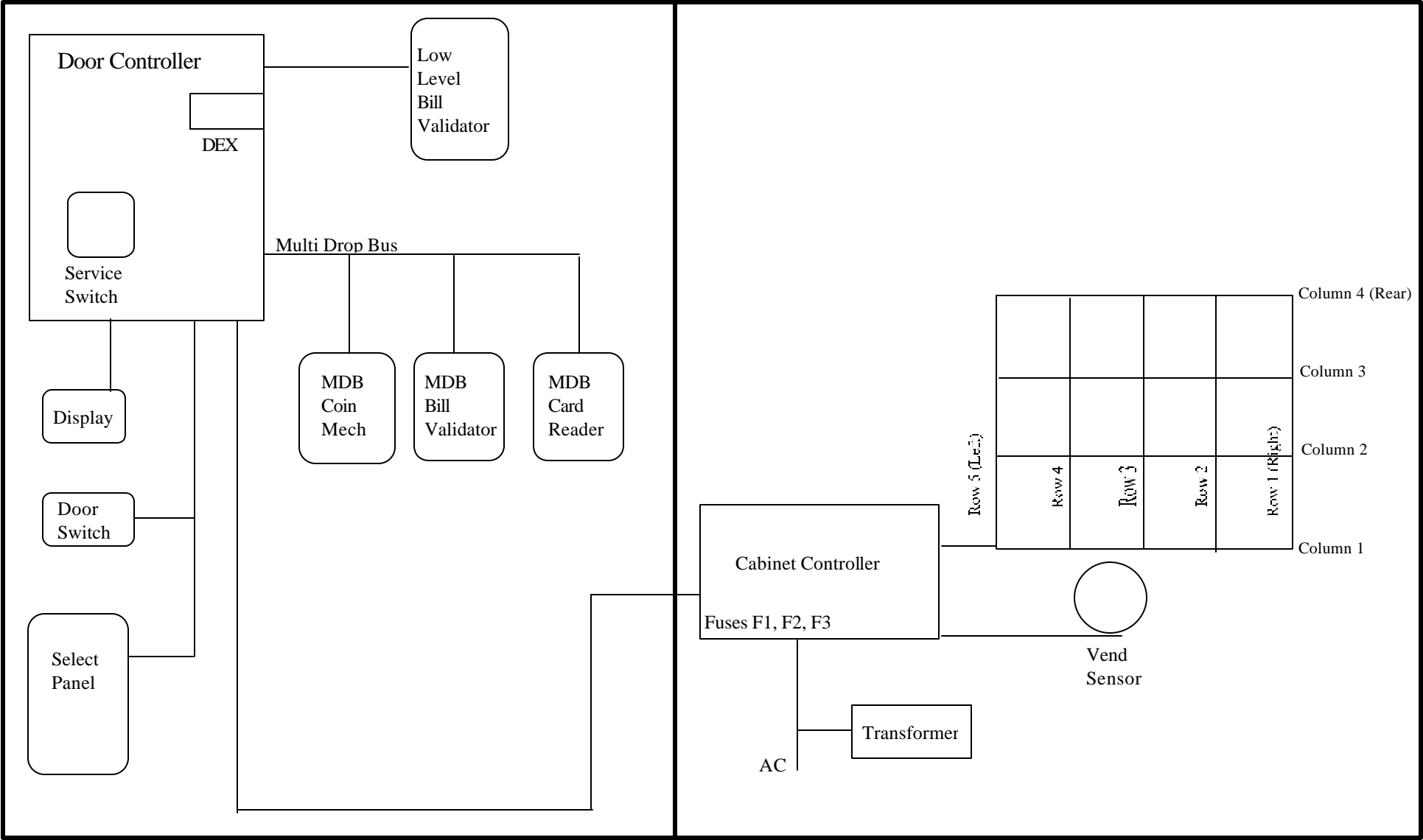

# Flex-Pak™ 3000 DeAmertek Controllers

**Door**

**Cabinet**

